

INSTALLATION MANUAL

SYSDRIVE 3G3FV-□-CE/3G3HV-□-CE

(€ (EC Directives Models)

Thank you for choosing this SYSDRIVE 3G3FV-□-CE/EF3HV-□-CE (EC Directives Models). This Installation Manual describes procedures for installing and wiring the SYSDRIVE 3G3FV-□-CE/EF3HV-□-CE (EC Directives Models).

Please read this manual thoroughly and handle and operate the product with care. For details about parameter settings required for operation, troubleshooting, and inspection methods, please refer to the User's Manual prepared for each series.

このたびは、SYSDRIVE 形3G3FV-□-CE/3G3HV-□-CE (EC指令対応機種)をお買い求めいただきまして、誠にありがとうございます。

この設置マニュアルは、SYSDRIVE 形3G3FV-□-CE/3G3HV-□-CEの設置および配線について記載しています。本マニュアルを必ずお読みいただき十分ご理解のうえ取扱いや操作を行ってください。(日本国内でご使用の際は和文マニュアルSCCY-305をご用意しています。)なお、運転のために必要なパラメータ、トラブル処理および点検方法については、各シリーズの取扱説明書を用意していますので併せてご覧ください。

NOTICE

1. This manual describes the functions of the product and relations with other products. You should assume that anything not described in this manual is not possible.
2. Although care has been given in documenting the product, please contact your OMRON representative if you have any suggestions on improving this manual.
3. The product contains potentially dangerous parts under the cover. Do not attempt to open the cover under any circumstances. Doing so may result in injury or death and may damage the product. Never attempt to repair or disassemble the product.
4. We recommend that you add the following precautions to any instruction manuals you prepare for the system into which the product is being installed.
 - Precautions on the dangers of high-voltage equipment.
 - Precautions on touching the terminals of the product even after power has been turned off. (These terminals are live even with the power turned off.)
5. Specifications and functions may be changed without notice in order to improve product performance.

Items to Check when Unpacking

Check the following items when removing the product from the package:

- Has the correct product been delivered (i.e., the correct model number and specifications)? Check the nameplate as shown below.

Inverter model	→	MODEL: 3G3FV-A4037-CE
Input specification	→	INPUT: AC3PH 360-460V 50Hz 360-460V 60Hz
Output specification	→	OUTPUT: AC3PH 0-460V 6.1kVA 11A
		LOT NO: NR5GA01-621-4 MASS: 4.5kg
		SER NO: W6C120-201-1
		MADE IN JAPAN MS

- Has the product been damaged in shipping?
- Are any screws or bolts loose?

Notice:

OMRON products are manufactured for use according to proper procedures by a qualified operator and only for the purposes described in this manual.

The following conventions are used to indicate and classify precautions in this manual. Always heed the information provided with them. Failure to heed precautions can result in injury to people or damage to the product.

 **DANGER** Indicates information that, if not heeded, is likely to result in loss of life or serious injury.

 **WARNING** Indicates information that, if not heeded, could possibly result in loss of life or serious injury.

 **Caution** Indicates information that, if not heeded, could result in relatively serious or minor injury, damage to the product, or faulty operation.

OMRON Product References

All OMRON products are capitalized in this manual. The word “Unit” is also capitalized when it refers to an OMRON product, regardless of whether or not it appears in the proper name of the product.

The abbreviation “Ch,” which appears in some displays and on some OMRON products, often means “word” and is abbreviated “Wd” in documentation in this sense.

The abbreviation “PC” means Programmable Controller and is not used as an abbreviation for anything else.

Visual Aids

The following headings appear in the left column of the manual to help you locate different types of information.

Note Indicates information of particular interest for efficient and convenient operation of the product.

© OMRON, 1997

All rights reserved. No part of this publication may be reproduced, stored in a retrieval system, or transmitted, in any form, or by any means, mechanical, electronic, photocopying, recording, or otherwise, without the prior written permission of OMRON.

No patent liability is assumed with respect to the use of the information contained herein. Moreover, because OMRON is constantly striving to improve its high-quality products, the information contained in this manual is subject to change without notice. Every precaution has been taken in the preparation of this manual. Nevertheless, OMRON assumes no responsibility for errors or omissions. Neither is any liability assumed for damages resulting from the use of the information contained in this publication.

Warning Label

A warning label is attached to the product as shown in the following illustration. Be sure to observe the precautionary items specified on the label.

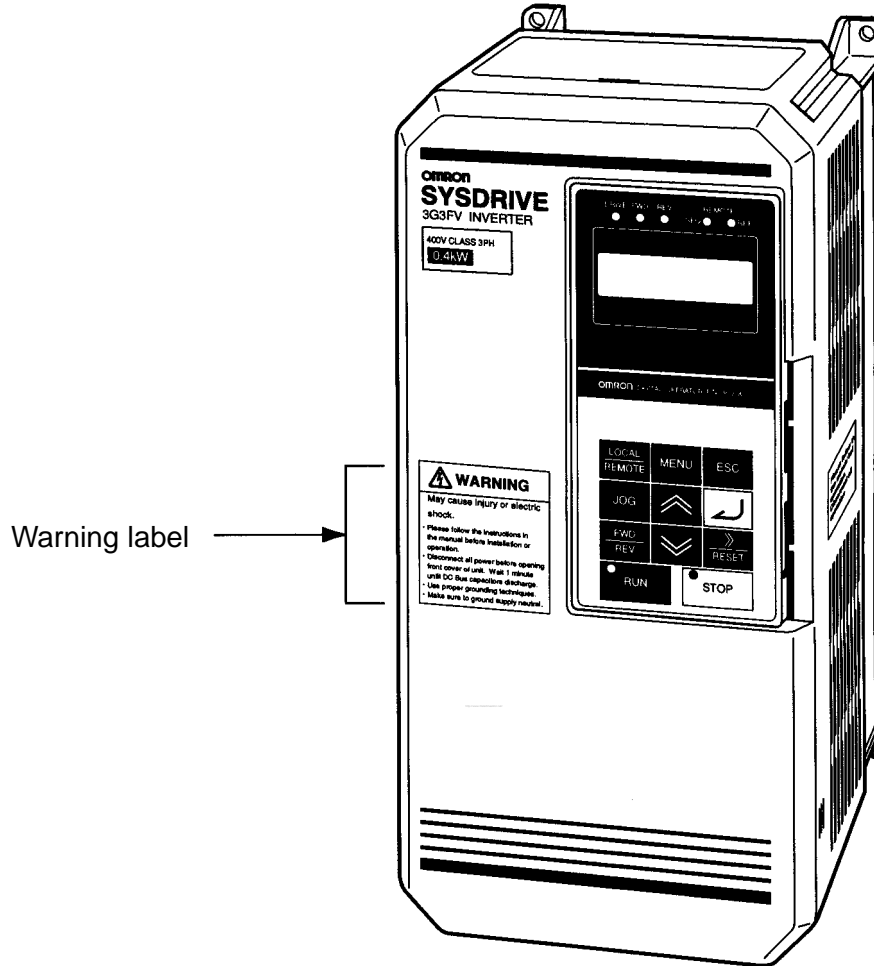

Contents of Warning Label

 WARNING
May cause injury or electric shock.
<ul style="list-style-type: none">• Please follow the instructions in the manual before installation or operation.• Disconnect all power before opening front cover of unit. Wait 1 minute until DC Bus capacitors discharge.• Use proper grounding techniques.• Make sure to ground supply neutral.

Table of Contents

Chapter 1. Introduction	1-1
1-1 Function	1-2
1-2 Nomenclature	1-5
Chapter 2. Installation	2-1
2-1 Mounting	2-2
2-1-1 Dimensions	2-2
2-1-2 Installation Conditions	2-7
2-2 Wiring	2-9
2-2-1 Removing and Mounting the Front Cover	2-10
2-2-2 Terminals	2-13
2-2-3 Standard Connection Diagram	2-18
2-2-4 Wiring Around the Main Circuit	2-23
2-2-5 Wiring Control Circuit Terminals	2-44
Chapter 3. Specifications	3-1
3-1 Inverter Specifications	3-2
3-2 Input Noise Filter Specification	3-6
Index	I-1
Revision History	R-1

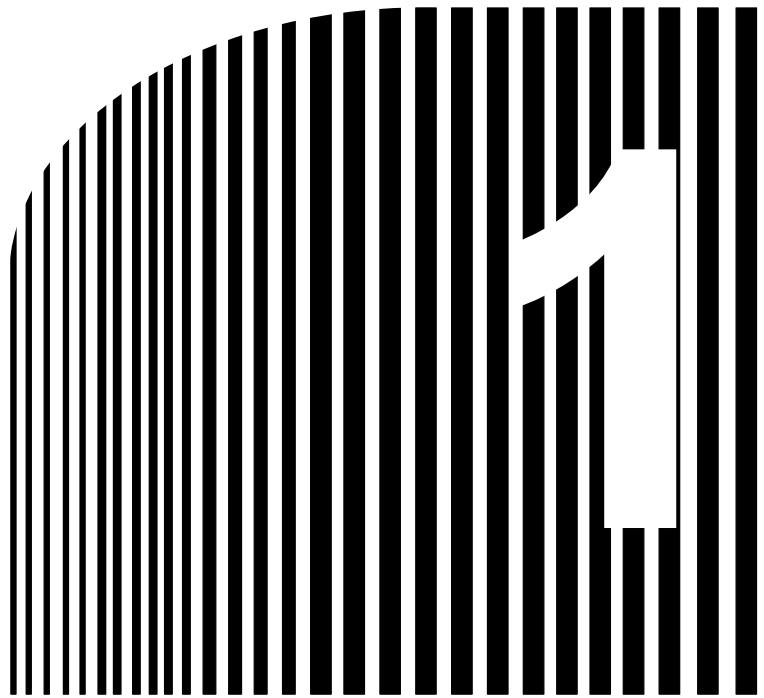

Chapter 1

• Introduction •

1-1 Function

1-2 Nomenclature

1-1 Function

■ SYSDRIVE 3G3FV-□-CE/3G3HV-□-CE (EC Directives) Inverter Models

- SYSDRIVE Inverter models include the 3G3FV Series and 3G3HV Series that conform to the CE mark.
- The maximum applied motor capacity ranges from 0.4 kW to 160 kW (18 models).

● 3G3FV Series

Voltage class	Protective structure	Maximum applied motor capacity	Model
400-V class (3-phase)	NEMA1 type	0.4 kW	3G3FV-A4004-CE
		0.75 kW	3G3FV-A4007-CE
		1.5 kW	3G3FV-A4015-CE
		2.2 kW	3G3FV-A4022-CE
		3.7 kW	3G3FV-A4037-CE
		5.5 kW	3G3FV-A4055-CE
		7.5 kW	3G3FV-A4075-CE
		11 kW	3G3FV-A4110-CE
	15 kW	3G3FV-A4150-CE	
	Open chassis type	18.5 kW	3G3FV-B4185-CE
		22 kW	3G3FV-B4220-CE
		30 kW	3G3FV-B4300-CE
		37 kW	3G3FV-B4370-CE
		45 kW	3G3FV-B4450-CE
		55 kW	3G3FV-B4550-CE
		75 kW	3G3FV-B4750-CE
		110 kW	3G3FV-B411K-CE
		160 kW	3G3FV-B416K-CE

● 3G3HV Series

Voltage class	Protective structure	Maximum applied motor capacity	Model
200-V class (single phase)	NEMA1 type	0.4 kW	3G3HV-AB004-CE
		0.75 kW	3G3HV-AB007-CE
		1.5 kW	3G3HV-AB015-CE
		2.2 kW	3G3HV-AB022-CE
		3.7 kW	3G3HV-AB037-CE
400-V class (3-phase)	NEMA1 type	0.4 kW	3G3HV-A4004-CE
		0.75 kW	3G3HV-A4007-CE
		1.5 kW	3G3HV-A4015-CE
		2.2 kW	3G3HV-A4022-CE
		3.7 kW	3G3HV-A4037-CE
		5.5 kW	3G3HV-A4055-CE
		7.5 kW	3G3HV-A4075-CE
		11 kW	3G3HV-A4110-CE
		15 kW	3G3HV-A4150-CE
	Open chassis type	18.5 kW	3G3HV-B4185-CE
		22 kW	3G3HV-B4220-CE
		30 kW	3G3HV-B4300-CE
		37 kW	3G3HV-B4370-CE
		45 kW	3G3HV-B4450-CE
		55 kW	3G3HV-B4550-CE
		75 kW	3G3HV-B4750-CE
		110 kW	3G3HV-B411K-CE
		160 kW	3G3HV-B416K-CE

■ Conformance to the LVD (Low-voltage Directives) and EMC Directives

The SYSDRIVE CE models conform to the LVD (prEN50178) and the EMC (EN50081-2, EN50082-2) Directives.

However, when the product is built into a unit, the connected switches, optional items, or motors may not satisfy these standards. In such a case, either use components that meet the standards or take appropriate countermeasures such as providing surge killers or other noise prevention devices.

■ Conformance Conditions

There are several conditions that must be satisfied for this Inverter to conform to the LVD and EMC Directives. To satisfy the standards, meet the instructions in this manual for the following installation conditions. If the Inverters are used beyond the conditions specified here, final confirmation must be made on the overall units.

- Installation of noise filters.
- Shield stranded cables must be used for input and output cables.
Limitations on the lengths of cables.
- Installation of metallic ground plates.
- Installation of recommended fuses on the input side.

■ Other Functions

Although this manual describes the installation methods for conforming to the LVD and EMC Directives, it does not describe the standard functions of the Inverter. For details, please refer to the User's Manual for each Series.

- 3G3FV Series: *SYSDRIVE 3G3FV High-function General-purpose Inverter (I516-E1)*
- 3G3HV Series: *SYSDRIVE 3G3HV High-capacity General-purpose Inverter (I515-E1)*

1-2 Nomenclature

■ Panel

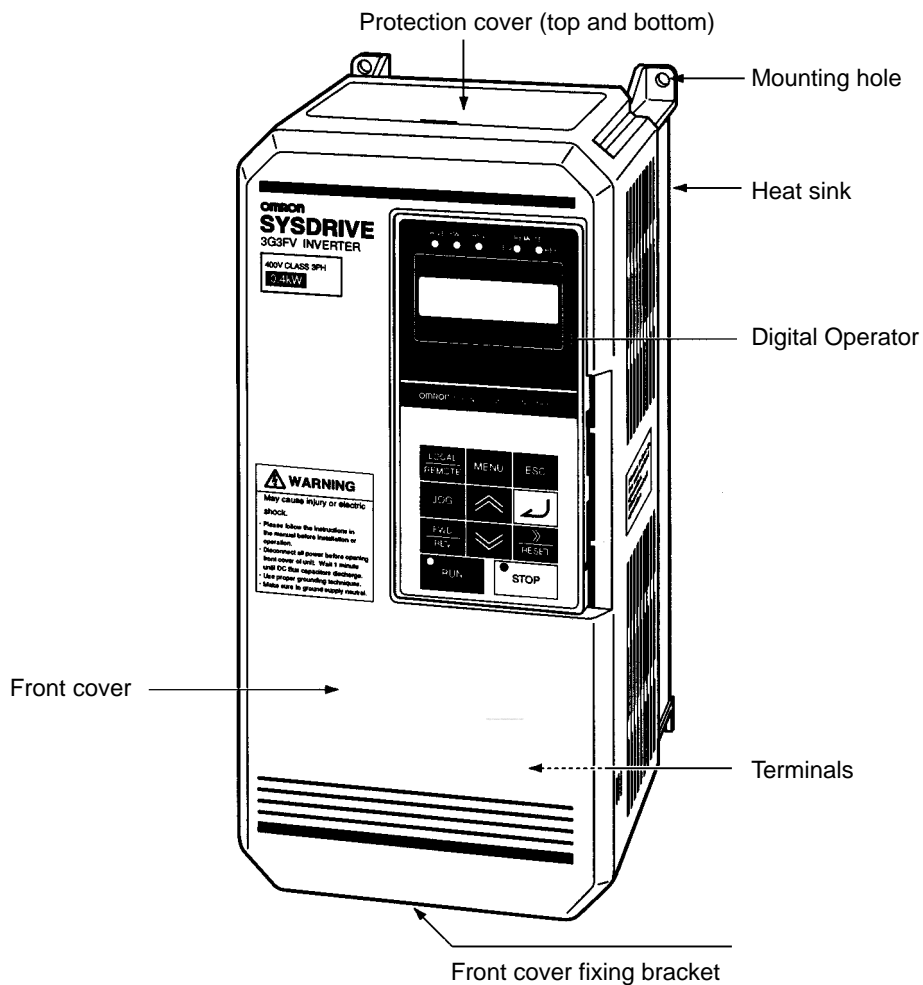

3G3FV Series

• Terminals (with Front Cover Removed)

3G3FV Series: 400-V Class Inverter with 3.7-kW Output

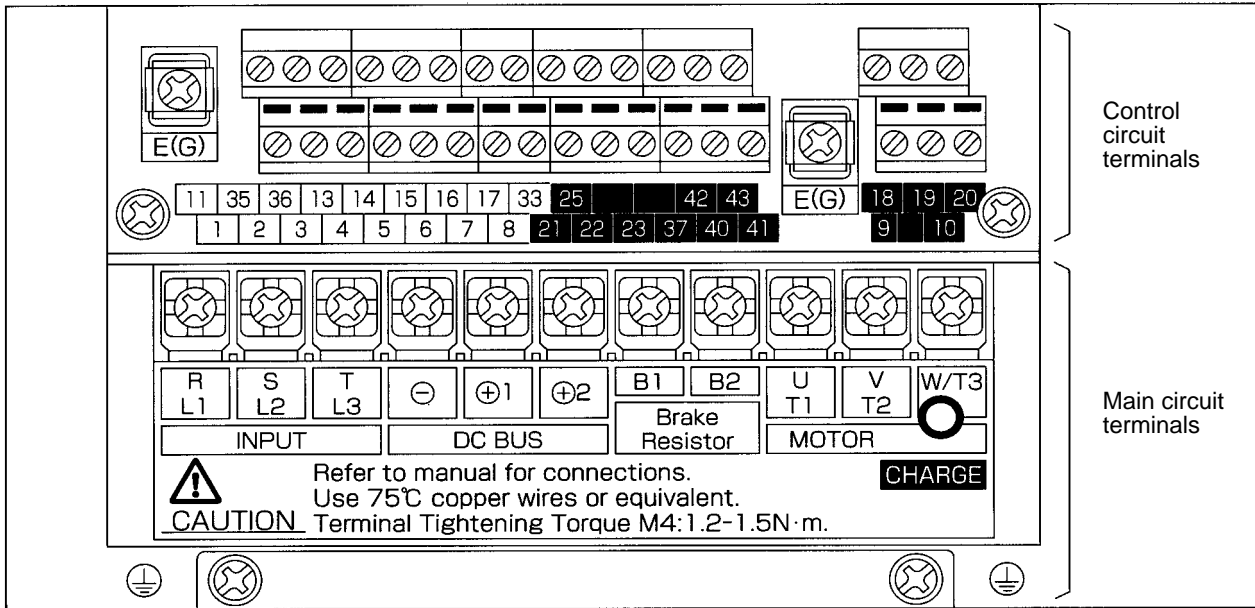

3G3HV Series: 400-V Class Inverter with 3.7-kW Output

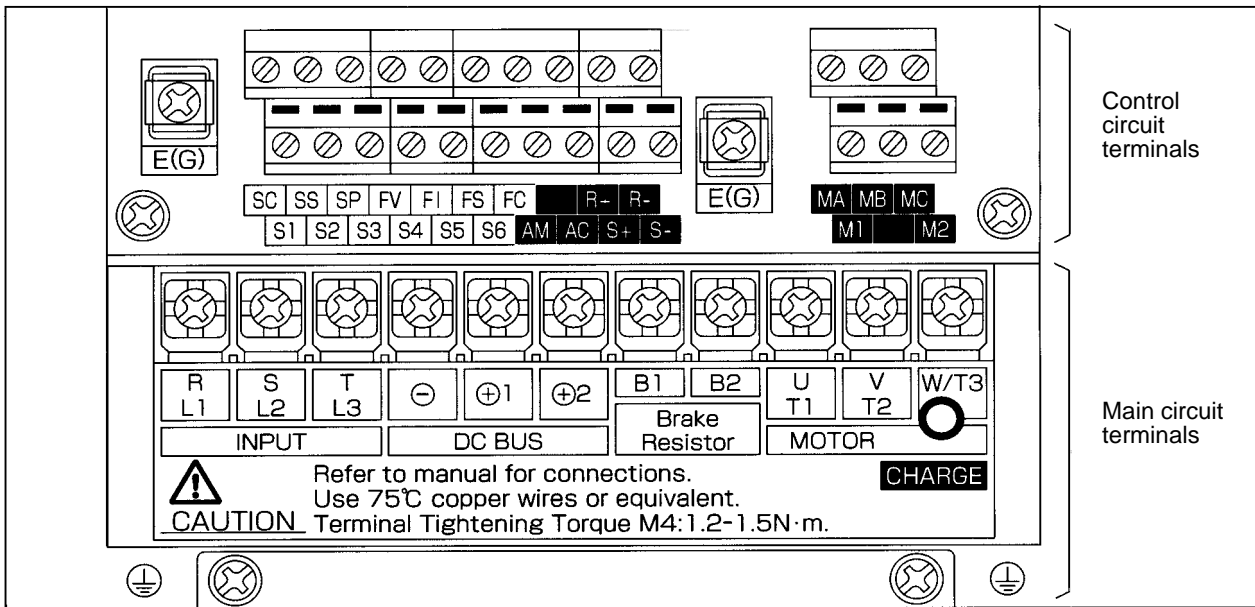

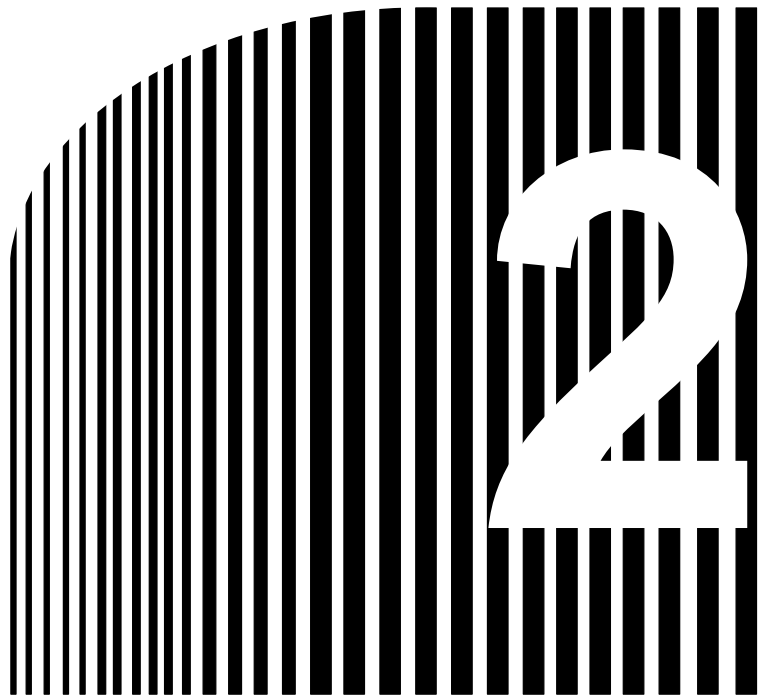

Chapter 2

• Installation •

2-1 Mounting

2-2 Wiring

2-1 Mounting

2-1-1 Dimensions

- 3G3FV-A4004-CE/-A4007-CE/-A4015-CE/-A4022-CE/-A4037-CE
 3G3HV-AB004-CE/-AB007-CE/-AB015-CE/-A4004-CE/-A4007-CE
 3G3HV-A4015-CE/-A4022-CE/-A4037-CE

● External Dimensions

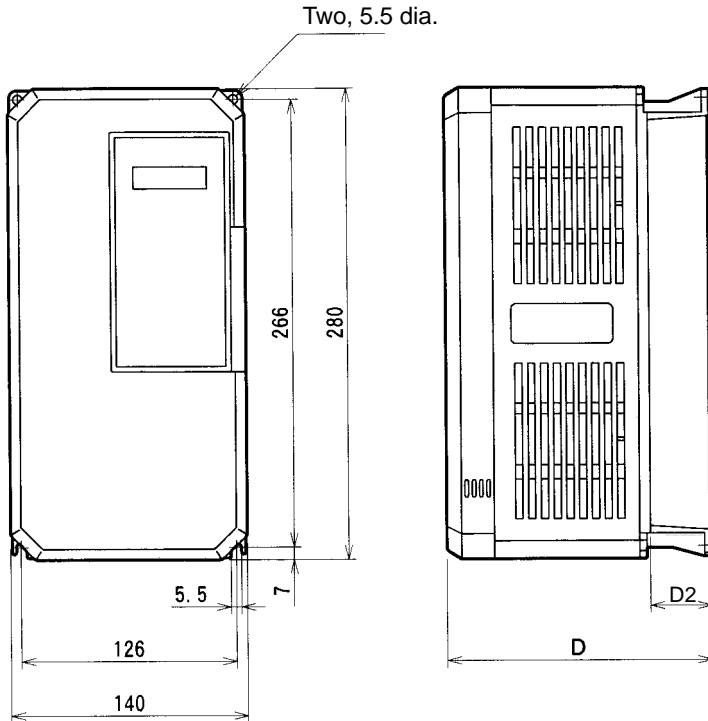

● Mounting Dimensions

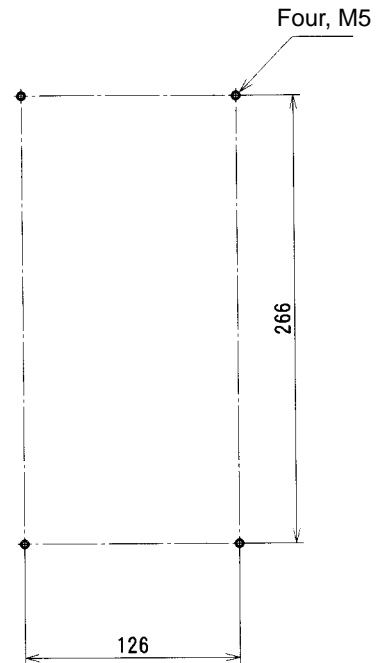

Series	Voltage class	Model 3G3FV-/3G3HV-	Dimensions (mm)	
			D	D2
3G3FV	400-V	A4004-CE/A4007-CE	160	39
		A4015-CE/A4022-CE/A4037-CE	180	59
3G3HV	200-V (single phase)	AB004-CE	160	39
		AB007-CE/AB015-CE	180	59
	400-V	A4004-CE/A4007-CE	160	39
		A4015-CE/A4022-CE/A4037-CE	180	59

■ 3G3FV-A4055-CE/-A4075-CE
3G3HV-AB022-CE/-AB037-CE/-A4055-CE/-A4075-CE

● External Dimensions

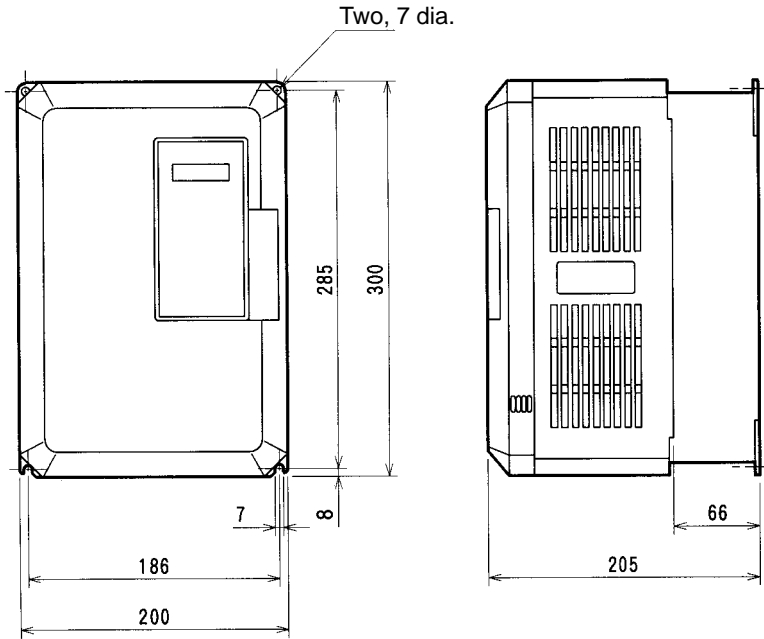

● Mounting Dimensions

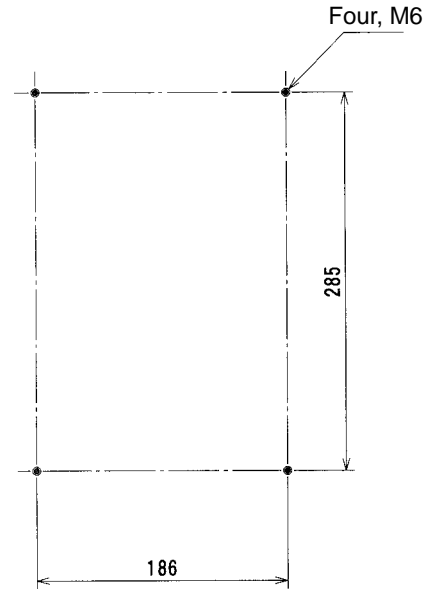

■ 3G3FV-A4110-CE/-A4150-CE
3G3HV-A4110-CE/-A4150-CE

● External Dimensions

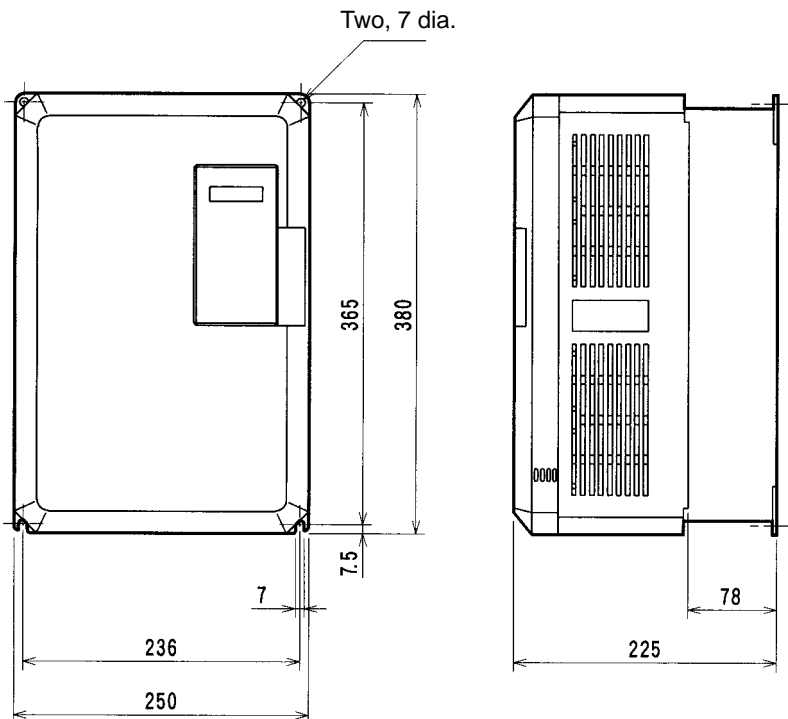

● Mounting Dimensions

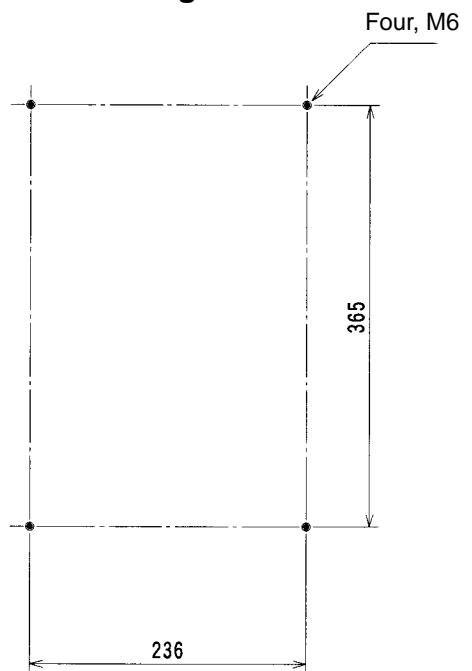

■ 3G3FV-B4185-CE/-B4220-CE/-B4300-CE/-B4450-CE
 3G3HV-B4185-CE/-B4220-CE/-B4300-CE/-B4450-CE

● External Dimensions

● Mounting Dimensions

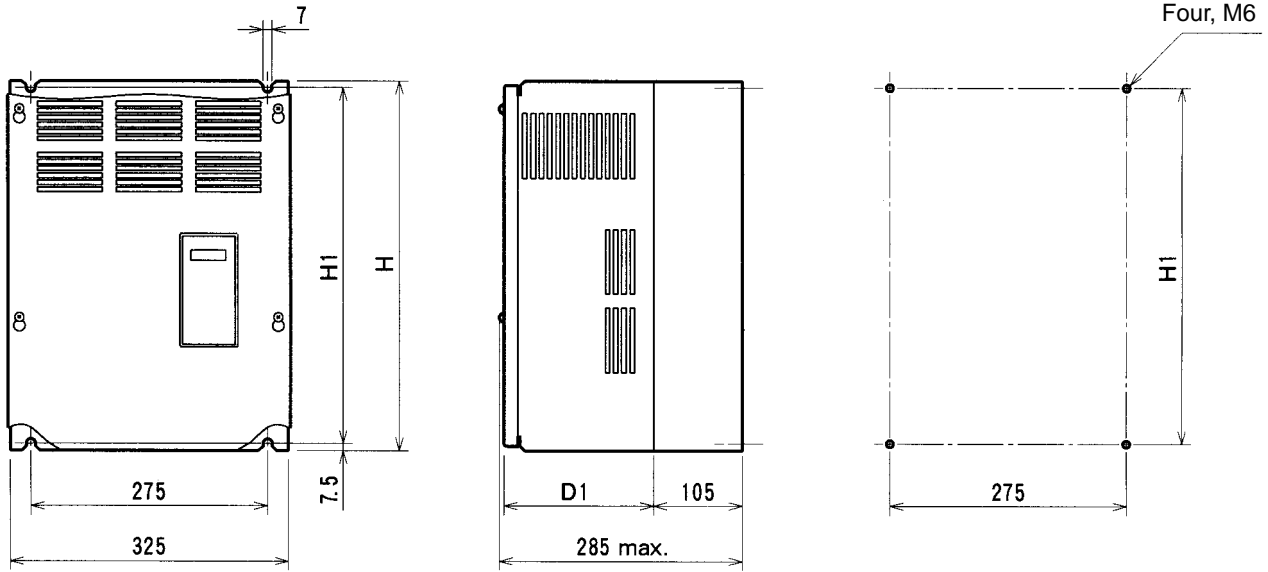

Series	Voltage class	Model 3G3FV-/3G3HV-	Dimensions (mm)		
			H	H1	D1
3G3FV	400-V	B4185-CE/B4220-CE	450	435	174.5
		B4300-CE/B4370-CE/B4450-CE	625	610	175
3G3HV	400-V	B4185-CE/B4220-CE	450	435	174.5
		B4300-CE/B4370-CE/B4450-CE	625	610	175

■ 3G3FV-B4550-CE/-B4750-CE
3G3HV-B4550-CE/-B4750-CE

● External Dimensions

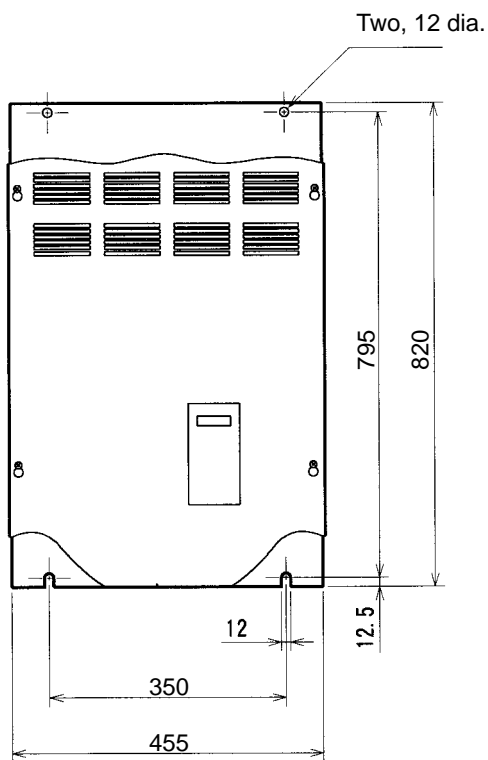

● Mounting Dimensions

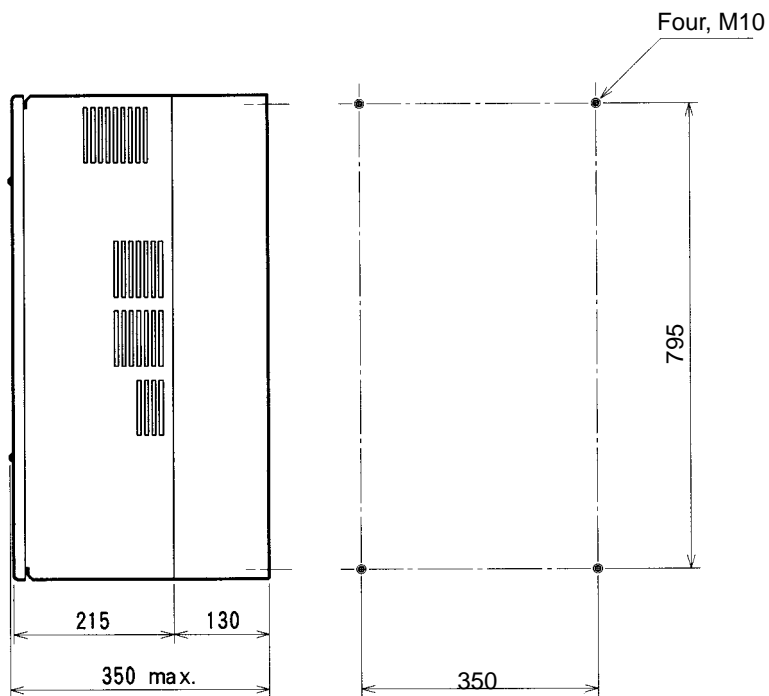

■ 3G3FV-B411K-CE/-B416K-CE
3G3HV-B411K-CE/-B416K-CE

● External Dimensions

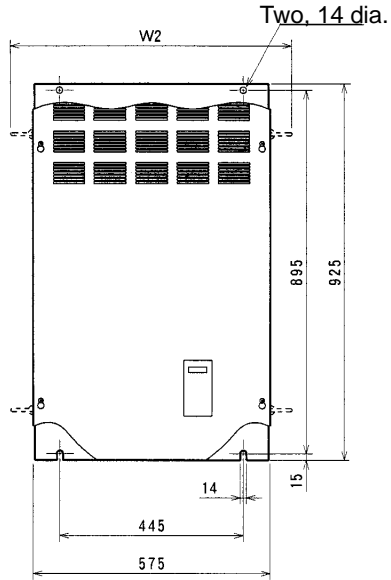

● Mounting Dimensions

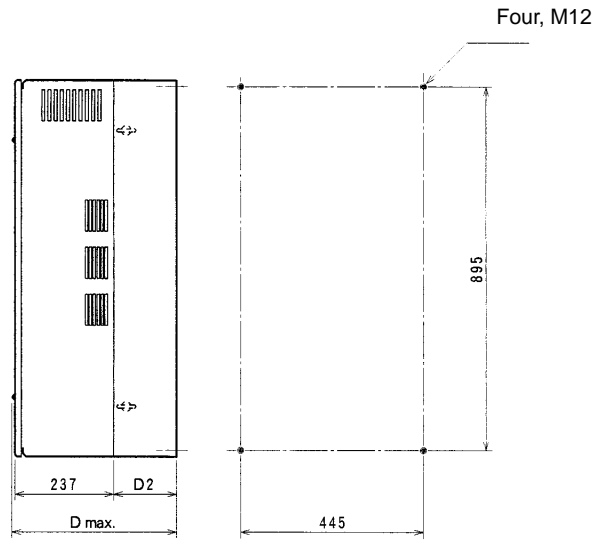

Series	Voltage class	Model 3G3FV-/3G3HV-	Dimensions (mm)		
			D	D2	W2
3G3FV	400-V	B411K	375	130	695
		B416K	400	158	695
3G3HV	400-V	B411K	375	130	695
		B416K	400	158	695

2-1-2 Installation Conditions

■ Cautions and Warnings

- ⚠ **Caution** Do not install the Inverter near combustible objects. Otherwise, a fire may occur.
- ⚠ **Caution** Do not install the Inverter in a place where it is exposed to dust or rubbish. Otherwise, a fire may occur.
- ⚠ **Caution** Prevent any foreign matter from entering into the Inverter. Otherwise, a fire or equipment trouble may occur.
- ⚠ **Caution** Provide specified spaces between the Inverter and the control panel and also between the Inverter and other units. Otherwise, a fire or equipment trouble may occur.
- ⚠ **Caution** Do not apply any strong impact to the Inverter. Otherwise, damage to the Inverter or cause equipment trouble may occur.
- ⚠ **WARNING** Install a stopping device for safety purposes. Otherwise, an injury may occur. (The holding brake is not a stopping device for safety purposes.)
- ⚠ **WARNING** Install an external emergency stop device so that the power supply can be turned OFF and operation can be stopped instantaneously in case of an emergency. Otherwise, an injury may occur.

■ Direction and Dimensions

- Install the Inverter on a vertical surface so that the characters on the nameplate are oriented upward.
- When installing the Inverter, always provide the following installation space to allow normal heat dissipation from the Inverter.

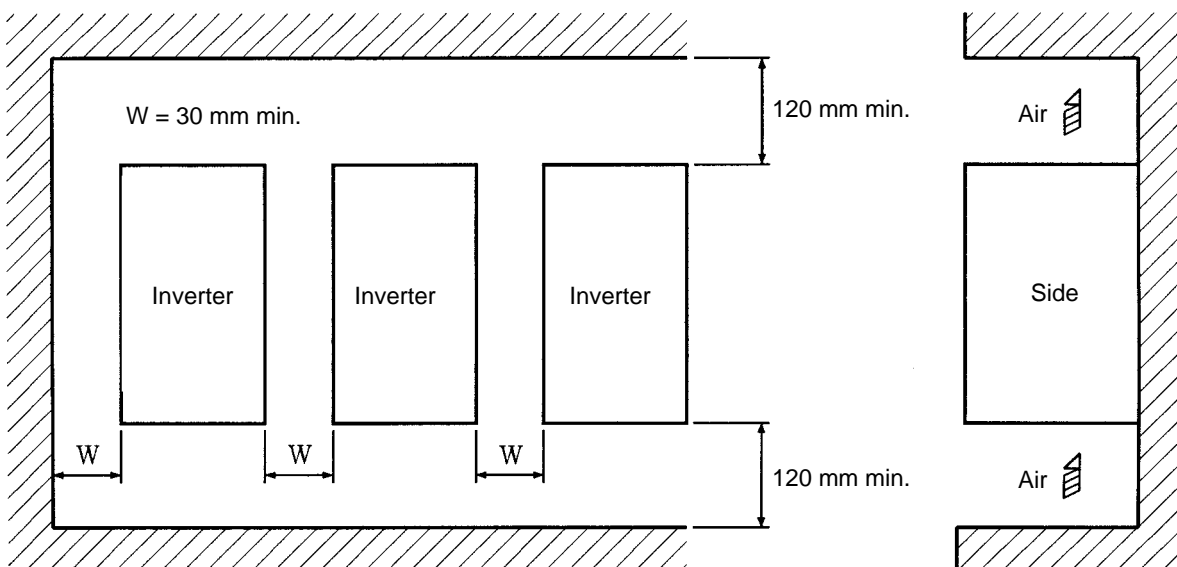

■ Installation Site

- Install the Inverter under the following conditions.

NEMA1 Type

Ambient temperature for operation: -10°C to 40°C

Humidity: 90% RH or less (no condensation)

Open Chassis Type

Ambient temperature for operation: -10°C to 45°C

Humidity: 90% RH or less (no condensation)

Note Remove the top and bottom covers when using the open chassis type of 15 kW or less.

- Install the Inverter in a clean location free from oil mist and dust. Alternatively, install it in a totally enclosed panel that is completely shielded from floating dust.
- When installing or operating the Inverter, always take special care so that metal powder, oil, water, or other foreign matter does not get into the Inverter.
- Do not install the Inverter on inflammable material such as wood.

■ Ambient Temperature Control











- To enhance operation reliability, the Inverter should be installed in an environment free from extreme temperature rises.
- If the Inverter is installed in an enclosed environment such as a box, use a cooling fan or air conditioner to maintain the internal air temperature below 45°C .

■ Protecting Inverter from Foreign Matter During Installation

- Place a cover over the Inverter during installation to shield it from metal powder produced by drilling.
- Upon completion of installation, always remove the cover from the Inverter. Otherwise, ventilation will be affected, causing the Inverter to overheat.

2-2 Wiring

■ Cautions and Warnings

-  **WARNING** Be sure that the power supply is turned OFF before wiring. Wait for at least one minute (three minutes for 30-kW or larger models) after turning off the power supply. Otherwise, an electric shock may occur.
-  **WARNING** Wiring must be performed by authorized persons specialized in electrical work. Otherwise, an electric shock or fire may occur.
-  **WARNING** Be sure to check for proper operation after wiring the emergency stop circuit. Otherwise, physical injury may occur.
-  **WARNING** Be sure to connect the ground to the supply neutral. Otherwise, an electric shock or equipment damage may occur.
-  **WARNING** Be sure to ground the ground terminal before connecting the other terminals. When removing the wiring, remove the ground wire last. Otherwise, an electric shock or fire may occur.
-  **WARNING** Be sure to confirm that the rated voltage of the Inverter coincides with the voltage of the AC power supply. Otherwise, a fire, injury, or equipment trouble may occur.
-  **WARNING** When connecting the braking resistor, Braking Resistor Unit, or Braking Unit, be sure to follow the instructions specified in the Operation Manual. Otherwise, a fire may occur.
-  **WARNING** Be sure to wire correctly. Otherwise, injury or equipment damage may occur.
-  **WARNING** Be sure to firmly tighten the screws on the terminal block. Otherwise, a fire, injury, or equipment damage may occur.
-  **Caution** Do not connect the AC power to the output terminal T1 (U), T2 (V), or T3 (W). Otherwise, equipment damage or trouble may occur.

2-2-1 Removing and Mounting the Front Cover

Remove the front cover to wire the terminals. Remove the Digital Operator from the front cover before removing the front cover. For models of 15 kW or less (both 200-V and 400-V class), do not remove or mount the front cover without first removing the Digital Operator; otherwise the Digital Operator may malfunction due to imperfect contact.

■ Removing the Cover (Models of 15 kW or Less)

• Removing the Digital Operator

Press the lever on the side of the Digital Operator in the arrow ① direction to unlock the Digital Operator and lift the Digital Operator in the arrow ② direction to remove the Digital Operator as shown in the following illustration.

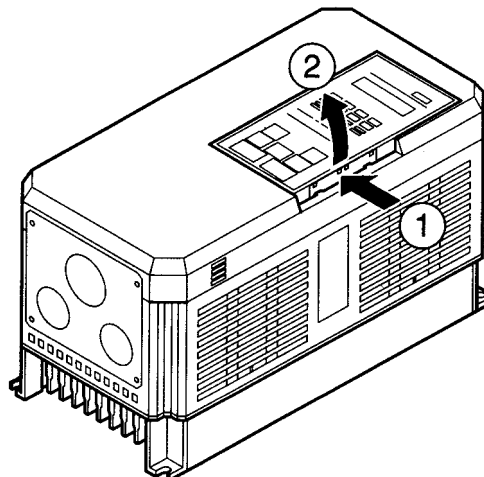
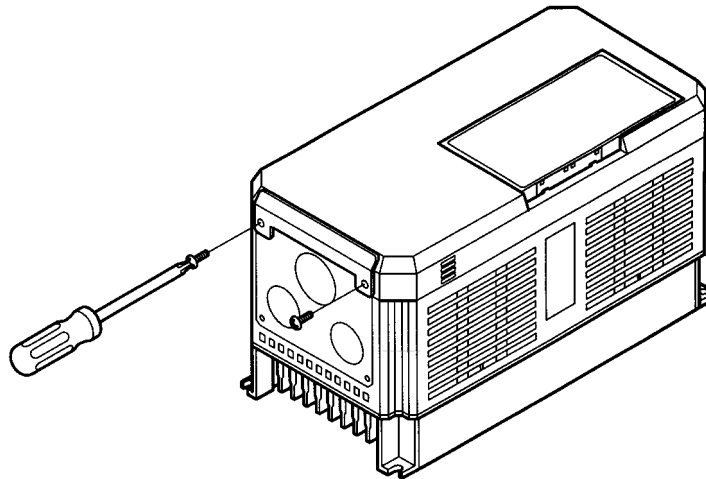

• Removing the Front Cover

Press the left and right sides of the front cover in the arrow ① directions and lift the bottom of the cover in the arrow ② direction to remove the front cover as shown in the following illustration.

1. Loosen the two screws for the front cover fixing bracket and remove the bracket.

2. While pressing the sides of the front cover, pull the front cover towards you.

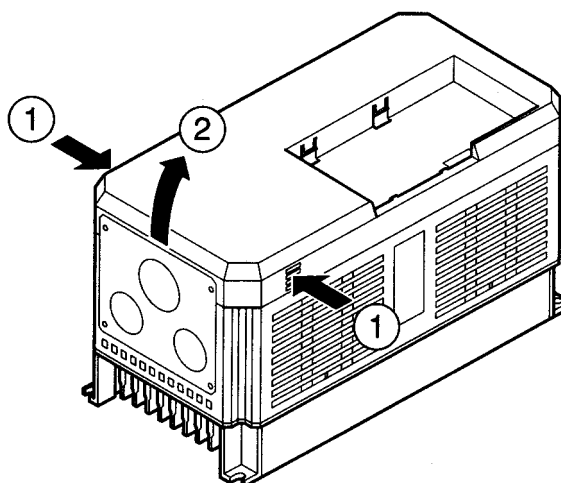

• **Mounting the Front Cover**

Mount the front cover to the Inverter by taking in reverse order to the steps to remove the front cover after wiring the terminals.

Do not mount the front cover with the Digital Operator attached to the front cover, otherwise Digital Operator may malfunction due to imperfect contact.

Insert the tab of the upper part of the front cover into the groove of the Inverter and press the lower part of the front cover onto the Inverter until the front cover snaps shut.

■ **Mounting the Digital Operator**

- Hook the Digital Operator on clicks A of the front cover in the arrow ① direction as shown in the following illustration.
- Press the Digital Operator in the arrow ② direction until it snaps shut with clicks B.

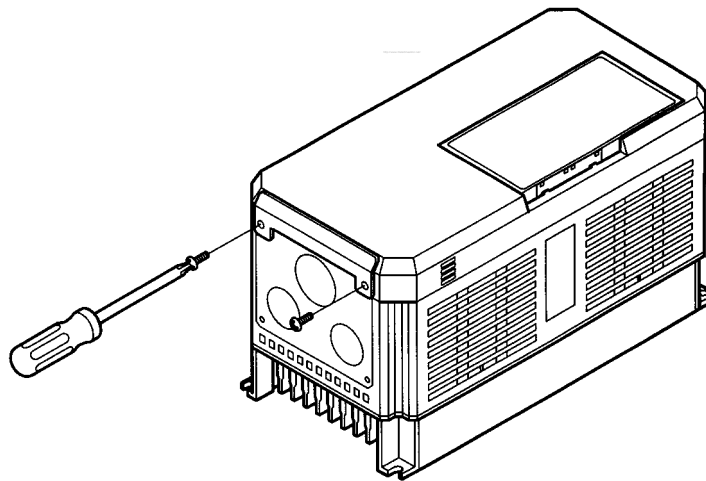
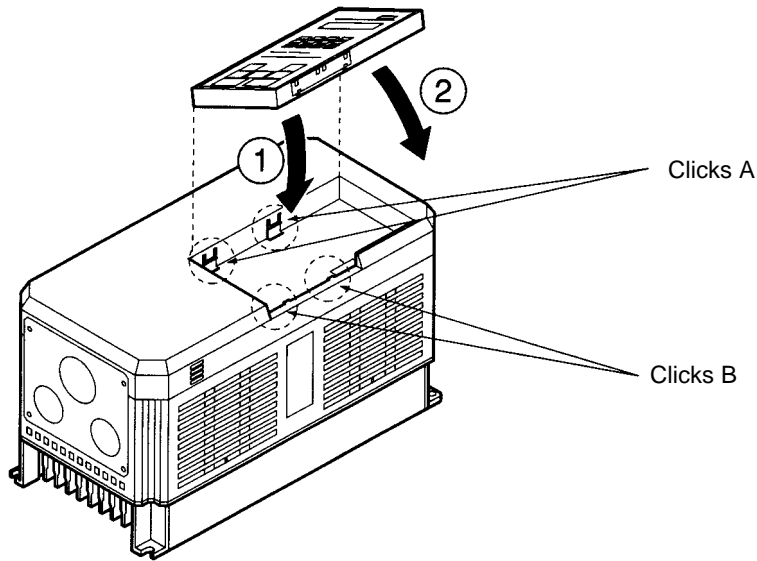

Note Do not remove or attach the Digital Operator or mount or remove the front cover using methods other than those mentioned above, otherwise the Inverter may malfunction due to imperfect contact or break.

■ **Removing the Front Cover of Inverters with 18.5-kW Output or More**

- The front cover can be removed without removing the Digital Operator from the Inverter provided that the Inverter model is one with an output of 18.5 kW or more.
- Loosen the four screws of the front cover and move the front cover slightly upwards to remove the front cover.

2-2-2 Terminals

■ 3G3FV Series

● Terminal Block Configuration (400-V Class with 3.7-kW Output, CE Models)

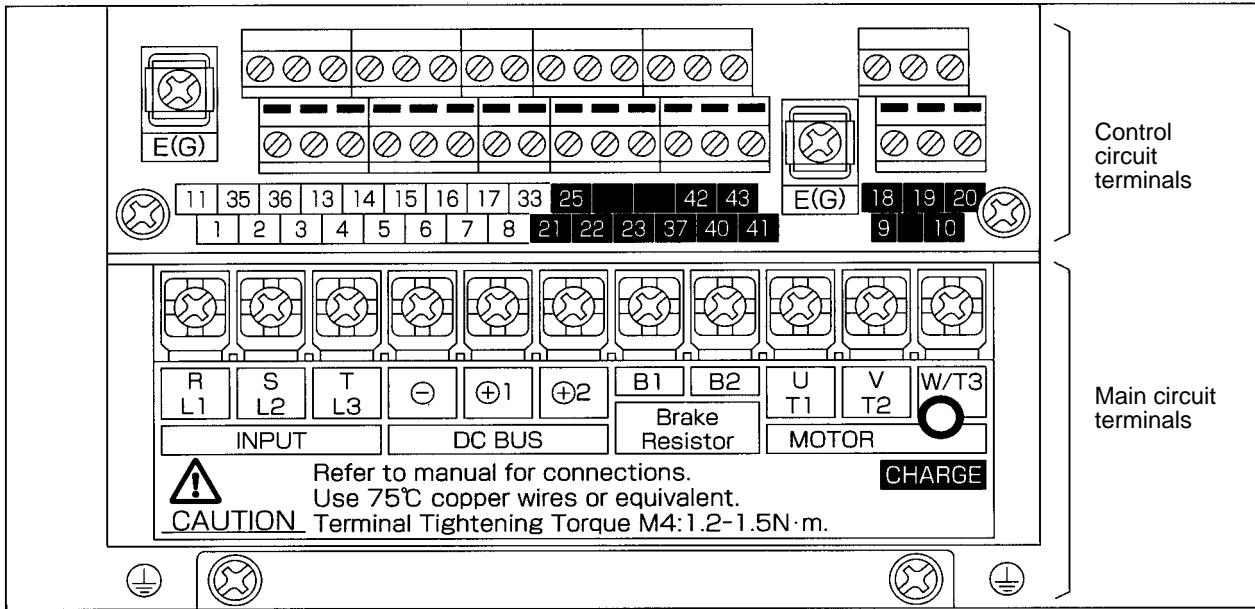

● Main Circuit Terminals

Voltage class	400-V class		
Model 3G3FV-	A4004 to A4150	B4185 to B4450	B4550 to B416K
Maximum applied motor capacity	0.4 to 15 kW	18.5 to 45 kW	55 to 160 kW
L1 (R)	Power supply input terminals, 3-phase, 380 to 460 VAC, 50/60 Hz		
L2 (S)			
L3 (T)			
T1 (U)	Motor output terminals, 3-phase, 380 to 460 VAC (correspond to input voltage)		
T2 (V)			
T3 (W)			
B1	Braking Resistor Unit connection terminals	---	
B2			
+ 1	DC reactor connection terminal (+ 1 - + 2)	DC power supply input terminal (+ 1 - -)	---
+ 2			
-	DC power supply input terminal (+ 1 - -)	Braking Unit connection terminal (+ 3 - -)	Braking Unit connection terminal (+ 3 - -) (see note 3)
+ 3			
s (I ₂)	---	Cooling fan power supply input terminal	---
r (I ₁)	---		See notes 1, 2
s200 (I ₂ 200)	---	---	---
s400 (I ₂ 400)	---	---	---
⊕	Ground the terminal at a resistance of less than 10 Ω.		

- Note 1.** These are the cooling fan power supply and control circuit power supply input terminals.
- Note 2.** When 200 V is used, input 200 to 230 VAC from r – s200. When 400 V is used, input 380 to 460 VAC from r – s400.
- Note 3.** Do not apply DC power to the Inverters with a capacity of 55 to 160 kW. Otherwise, equipment damage may occur.

● **Control Circuit Terminals for All 3G3FV-□-CE Models**

Symbol	Name	Function	Signal level
Se- quence input	1	Forward run/Stop	Forward run at ON. Stops at OFF.
	2	Reverse run/Stop	Reverse run at ON. Stops at OFF.
	3	Multi-function contact input 1	Set by parameter H1-01 (external fault a).
	4	Multi-function contact input 2	Set by parameter H1-02 (fault reset).
	5	Multi-function contact input 3	Set by parameter H1-03 (multi-step refer- ence 1).
	6	Multi-function contact input 4	Set by parameter H1-04 (multi-step refer- ence 2).
	7	Multi-function contact input 5	Set by parameter H1-05 (jog frequency refer- ence)
	8	Multi-function contact input 6	Set by parameter H1-06 (external base- block N.O.)
	11	Sequence input common	Common for 1 to 8.
	35	Sequence switching terminal	NPN/PNP input switching terminal
	36	Sequence power +24V	Power common for 1 to 8
Analog input	15	Frequency reference power supply (15 VDC)	15-VDC power supply for frequency refer- ence.
	33	Frequency reference power supply (-15 VDC)	-15-VDC power supply for frequency refer- ence.
	13	Frequency reference input (voltage)	Frequency reference voltage input terminal Either 0 to +10 V or 0 to ±10 V can be se- lected as the parameter (H3-01).
	14	Frequency reference input (current)	Current input terminal for frequency refer- ence.
	16	Multi-function analog input	Set by parameter H3-05.
	17	Frequency reference input common	Common for analog input signal.
Shield	E	Shielded wire connecting ground	For connecting to shielded wires
Se- quence output	9	Multi-function contact output (NO condi- tion)	Set by parameter H2-01 (during running).
	10	Multi-function contact output common	
	25	Multi-function output 1	Set by parameter H2-02 (zero speed detection).
	27	Multi-function output 1 common	
	26	Multi-function output 2	Set by parameter H2-03 (agree output refer- ence detection).
	37	Multi-function output 2 common	
	18	Fault output (NO condition)	When fault occurs: Terminals 18 to 20: Closed
	19	Fault output (NC condition)	Terminals 19 to 20: Open
	20	Fault output common	
			Photocoupler 24 VDC, 8 mA
			15 VDC, 20 mA max.
			-15 VDC, 20 mA max.
			0 to 10 VDC (20 kΩ) 0 to ±10 V (20 kΩ)
			4 to 20 mA (250 kΩ)
			0 to 10 VDC (20 kΩ) 0 to ±10 V (20 kΩ)

			Contact output (SPST-NO) 30 VDC, 1 A max. 250 VAC, 1 A max.
			Open collector output 48 V, 50 mA max.
			Contact output (SPDT) 30 VDC, 1 A max. 250 VAC, 1 A max.

Symbol	Name	Function	Signal level
Analog output	21	Multi-function analog output 1	0 to ±10 VDC, 0 to 10 VDC, 2 mA max.
	23	Multi-function analog output 2	
	22	Multi-function analog output common	
---	40	For option	
	41		
	42		
	43		

Note The settings shown in parentheses in the “Function” column for the multi-function inputs and multi-function contact outputs indicate default settings.

■ 3G3HV Series

● Terminal Block Configuration (400-V Class with 3.7-kW Output, CE Models)

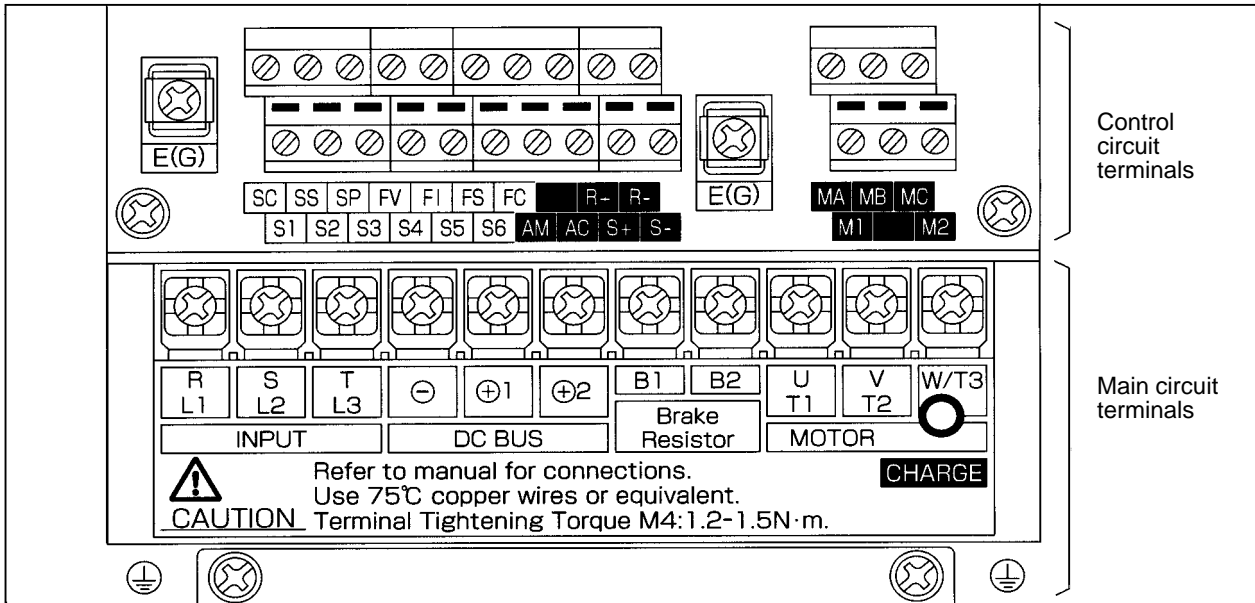

● Main Circuit Terminals

Voltage class	200-V class	400-V class	
Model 3G3HV-	AB004 to AB037	A4004 to A4150	B4185 to B416K
Maximum applied motor capacity	0.4 to 3.7 kW	0.4 to 15 kW	18.5 to 160 kW
L (R)	Power supply input terminals, single phase, 200 to 230 VAC, 50/60 Hz	---	
N (S)		---	
L1 (R)	---	Power supply input terminals, 3-phase, 380 to 460 VAC, 50/60 Hz	Power supply input terminals, 3-phase, 380 to 460 VAC, 50/60 Hz
L2 (S)			
L3 (T)			
L11 (R1)		---	
L21 (S1)			
L31 (T1)			
T1 (U)	Motor output terminals, 3-phase, 200 to 230 VAC (correspond to input voltage)	Motor output terminals, 3-phase, 380 to 460 VAC (correspond to input voltage)	
T2 (V)			
T3 (W)			
B1	Braking Resistor Unit connection terminals	Braking Resistor Unit connection terminals	---
B2			
⊖	DC reactor connection terminal (⊕ 1-⊕2)	DC reactor connection terminal (⊕ 1-⊕2)	---
⊕ 1			
⊕ 2	DC power supply input terminal (⊕ 1-⊖)	DC power supply input terminal (⊕ 1-⊖)	
⊕	Ground the terminal at a resistance of less than 100 Ω.	Ground the terminal at a resistance of less than 10 Ω.	

● Control Circuit Terminals for All 3G3HV-□-CE Models

Symbol		Name	Function (see note)	Signal level
Se- quence input	S1	Forward run/Stop	Stops at OFF.	Photocoupler 24 VDC, 8 mA
	S2	Multi-function input 1 (S2)	Set by constant n035 (reverse run/stop).	
	S3	Multi-function input 2 (S3)	Set by constant n036 (external error a).	
	S4	Multi-function input 3 (S4)	Set by constant n037 (error reset).	
	S5	Multi-function input 4 (S5)	Set by constant n038 (multi-step speed reference 1).	
	S6	Multi-function input 5 (S6)	Set by constant n039 (multi-step speed reference 2).	
	SC	Sequence input common	Common for S1 to S6.	
	SS	Sequence switching terminal	NPN/PNP input switching terminal	
	SP	Sequence power +24V	Power common for S1 to S8	
Analog input	FS	Frequency reference power supply	DC power supply for frequency reference	15 VDC 20 mA max.
	FV	Frequency reference input (voltage)	Frequency reference voltage input terminal	0 to 10 VDC (20 kΩ)
	FI	Frequency reference input (current)	Current input terminal for frequency reference	4 to 20 mA (250 kΩ)
	FC	Frequency reference input common	Common for FV, FI	---
Shield	E (G)	Shielded wire connecting ground	For connecting to shielded wires	---
Se- quence output	MA	Multi-function contact output 1 (normally open)	Set by constant n040 (error)	Contact output 30 VDC, 1 A max. 250 VAC, 1 A max.
	MB	Multi-function contact output 1 (normally closed)		
	MC	Multi-function contact output 1 common	Common for MA, MB	
	M1	Multi-function contact output 2 (normally open)	Set by constant n041 (running)	
	M2	Multi-function contact output 2 common	Common for M1	
Analog output	AM	Multi-function analog output	Set by constant n048 (output frequency)	0 to 10 VDC, 2 mA
	AC	Multi-function analog output common	Common for AM	
---	R+	For option		
	R-			
	S+			
	S-			

Note The setting shown in parentheses in the “Function” column for the multi-function inputs and multi-function contact outputs indicate default settings.

2-2-3 Standard Connection Diagram

■ Main Circuit Terminal Connections

● 3G3FV Model

3G3FV-A4004 to A4150

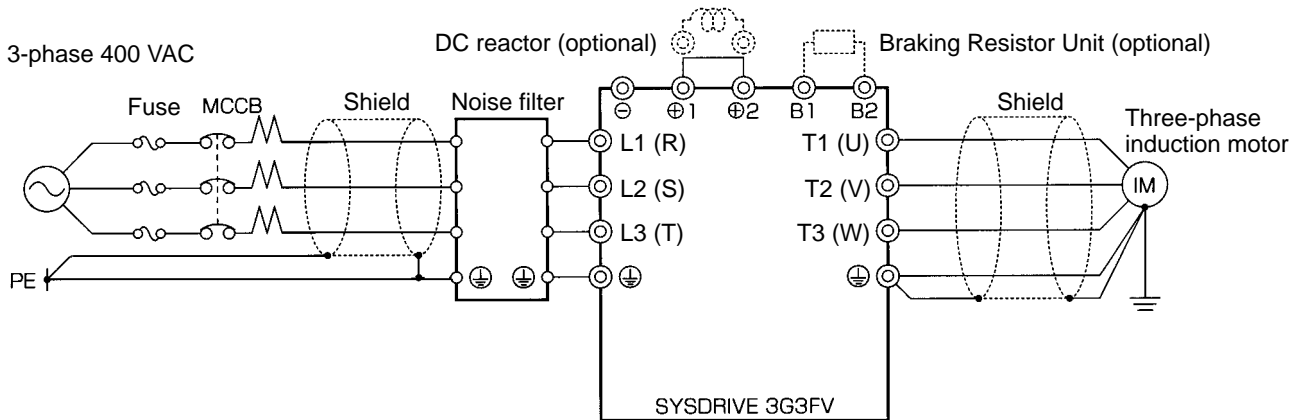

Note Be sure to remove the short bar before connecting a DC reactor.

3G3FV-B4185 to B4450

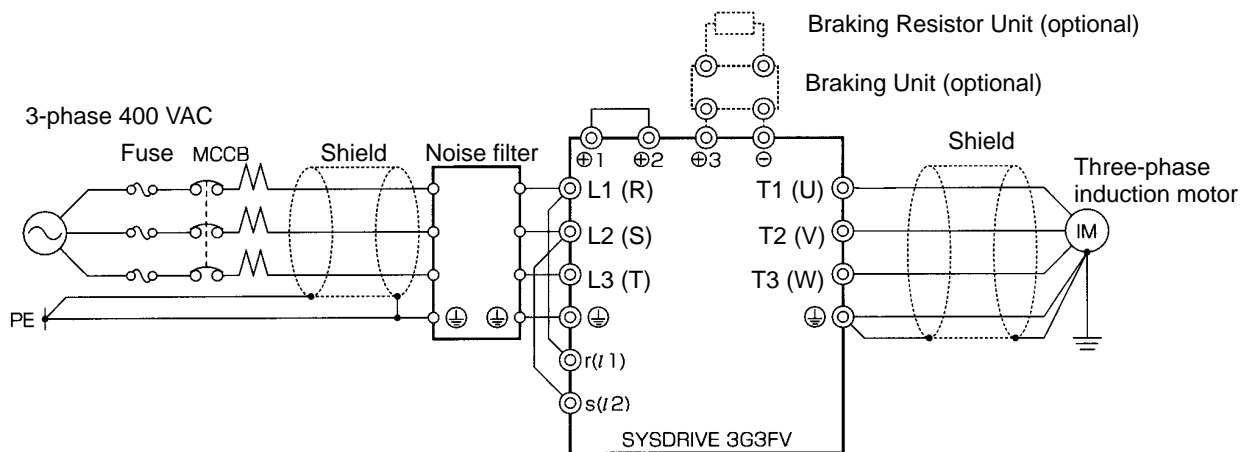

Note 1. The DC reactor is built in.

Note 2. The r-L1(R) and s-L2(S) terminals are short-circuited for shipping.

3G3FV-B4550 to B416K

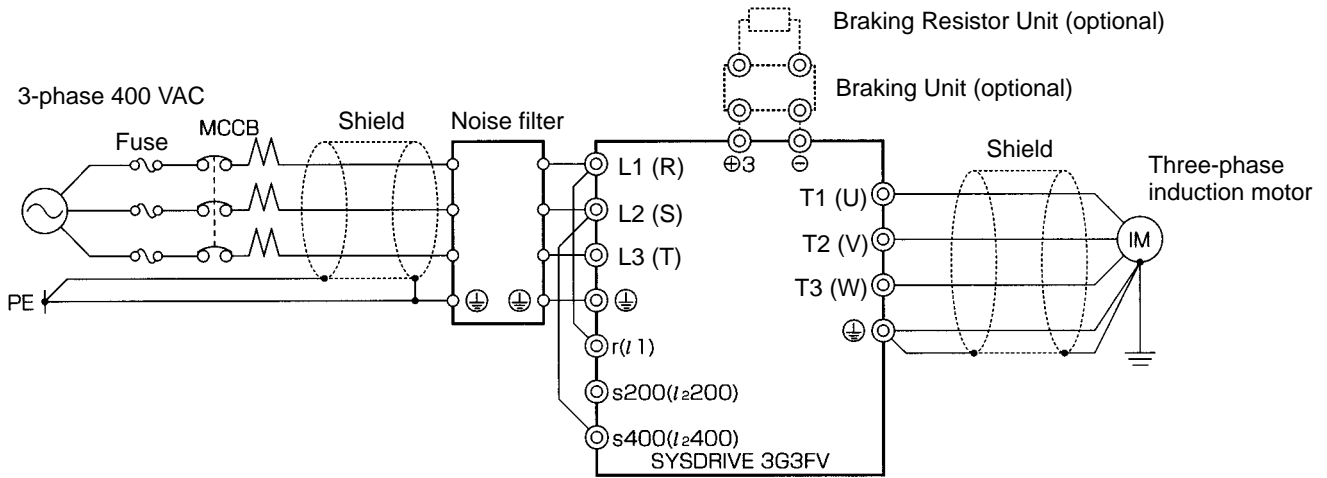

Note 1. The DC reactor is built in.

Note 2. The r-L1(R) and s(s400)-L2(S) terminals are short-circuited for shipping.

● **3G3HV Model**

3G3HV-AB004 to AB037, A4004 to A4150

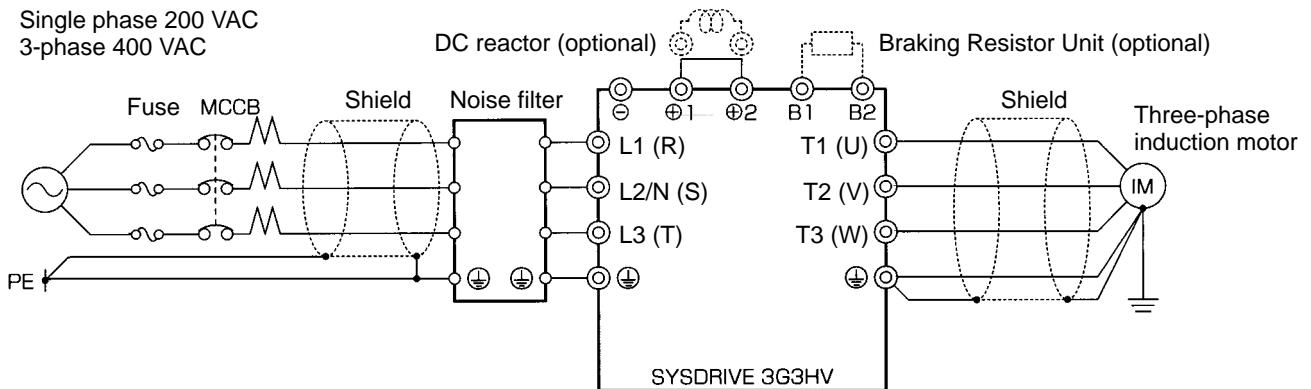

Note 1. Be sure to remove the short bar before connecting a DC reactor.

Note 2. Connect between L1 (R) and N (S) for the input of the 200-VAC single phase.

3G3HV-B4185 to B416K

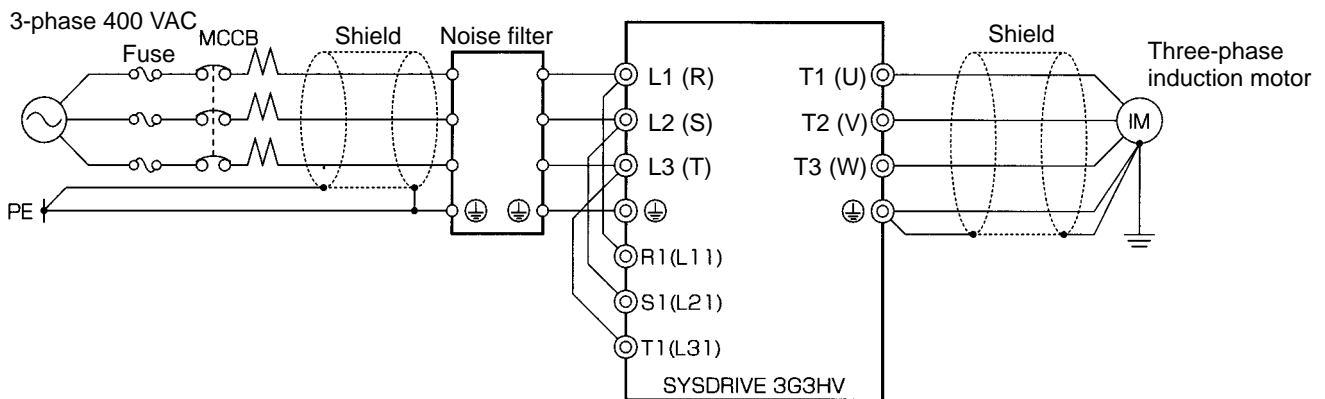

Note 1. Be sure to remove the short bar before connecting a DC reactor.

Note 2. The R1 (L11)-R (1),S1 (L21)-S (L2), and T1(L31)-T(L3) terminals are short-circuited for shipping.

General Notes

Note 1. The Braking Unit and Braking Resistor Unit cannot be connected to the 3G3HV Inverters of 18.5 kW to 160 kW.

Note 2. Make sure that terminals L1 and L11, L2 and L21, L3 and L31 are short-circuited. These terminals are short-circuited with short bars before shipping. Be sure to remove the short bars, however, when using 12-pulse rectification.

■ Control Circuit Terminal Connections (All Models)

● 3G3FV Model

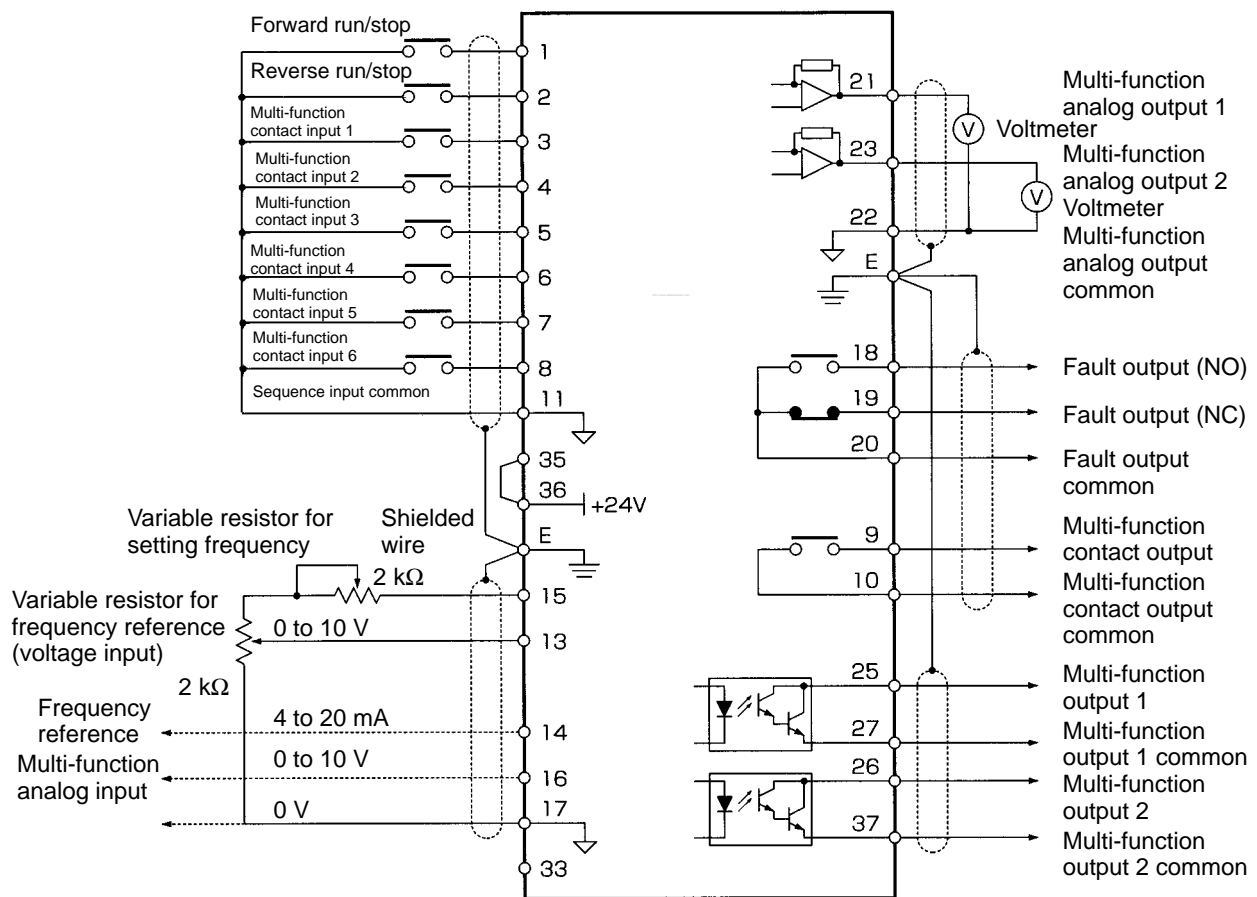

● 3G3HV Model

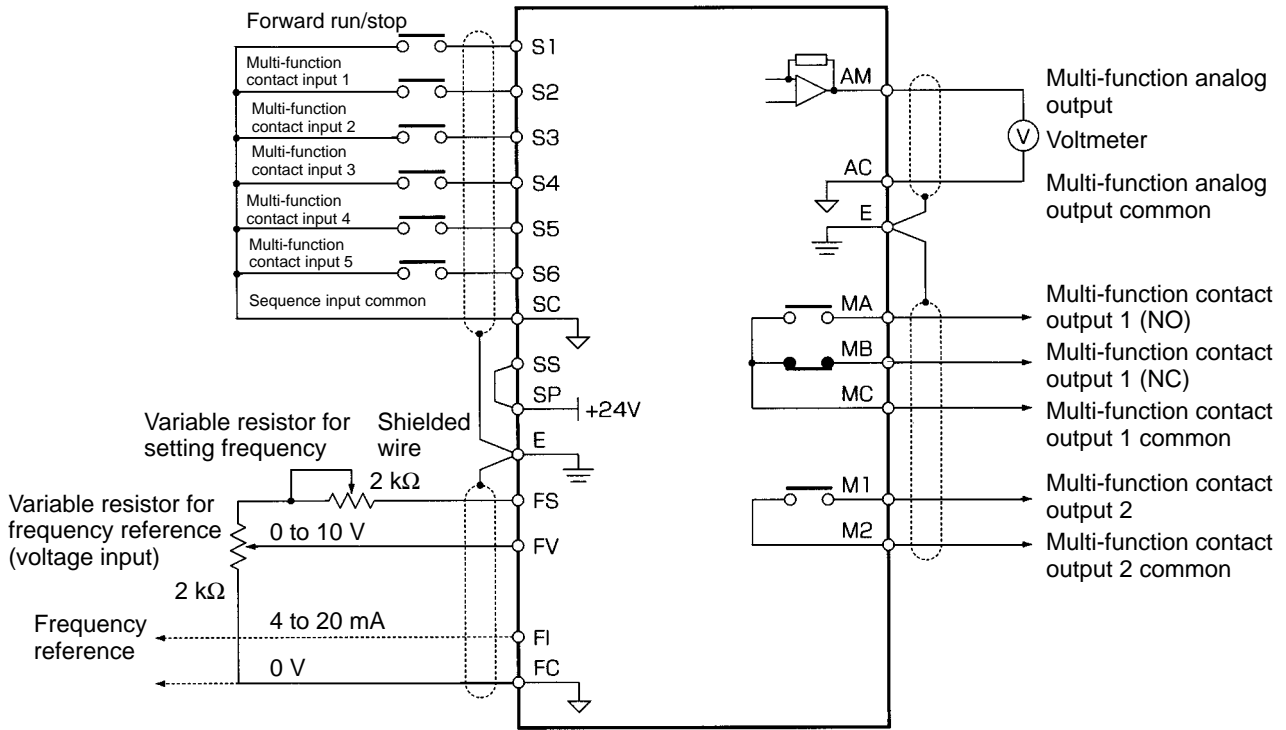

■ Input Methods of Control Circuit Terminals

● When Using a PNP Transistor (Open Collector) for Control Signals

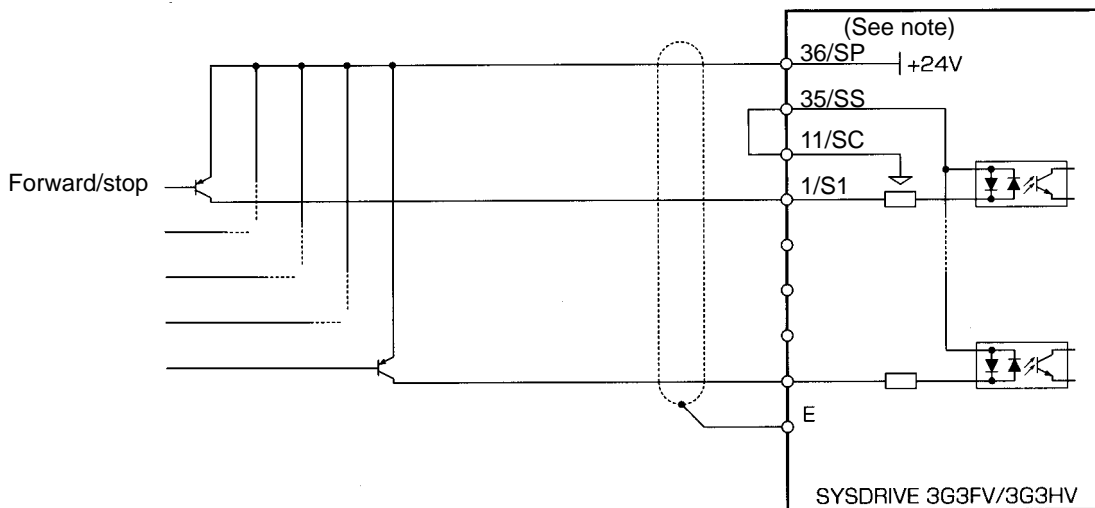

Note Numeric characters indicate terminal numbers for the 3G3FV and alphanumeric characters indicate terminal numbers for the 3G3HV.

• When Using a NPN Transistor (Open Collector) for Control Signals

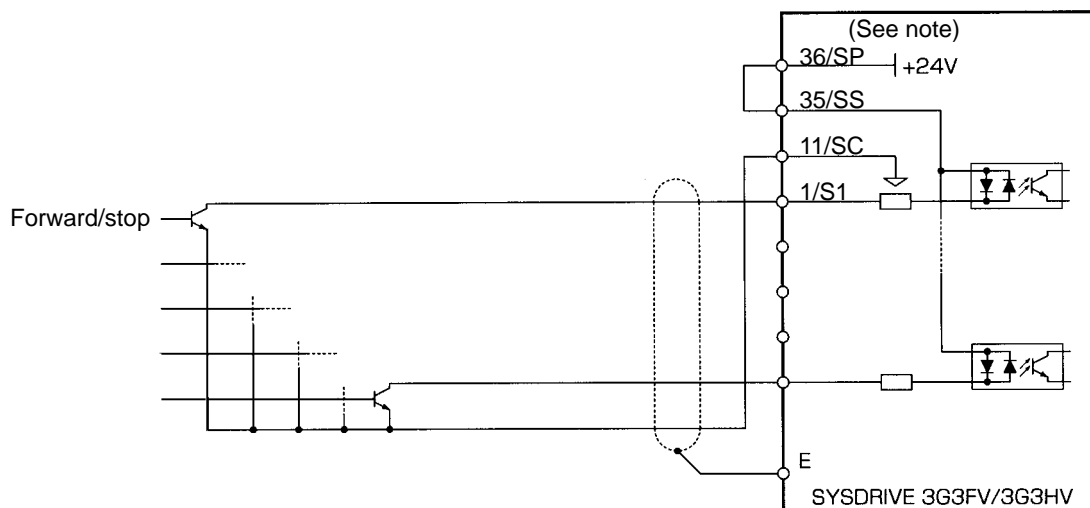













Note Numeric characters indicate terminal numbers for the 3G3FV and alphanumeric characters indicate terminal numbers for the 3G3HV.





2-2-4 Wiring Around the Main Circuit

System reliability and noise resistance are affected by the wiring method used. Therefore, always follow the instructions given below when connecting the Inverter to peripheral devices and other parts.





■ Wire Size and Round Solderless Terminal

● Wire Sizes

Model 3G3FV/3G3HV -□-CE	Terminal	Terminal screw	Wire thickness (mm ²)
A4004	L1, L2, L3, (-), (+)1, (+)2, B1, B2, U (T1), V (T2), W (T3)	M4	2 to 5.5
			
A4007	L1, L2, L3, (-), (+)1, (+)2, B1, B2, U (T1), V (T2), W (T3)	M4	2 to 5.5
			
A4015	L1, L2, L3, (-), (+)1, (+)2, B1, B2, U (T1), V (T2), W (T3)	M4	2 to 5.5
			
A4022	L1, L2, L3, (-), (+)1, (+)2, B1, B2, U (T1), V (T2), W (T3)	M4	2 to 5.5
			
A4037	L1, L2, L3, (-), (+)1, (+)2, B1, B2, U (T1), V (T2), W (T3)	M4	2 to 5.5
			
A4055	L1, L2, L3, (-), (+)1, (+)2, B1, B2, U (T1), V (T2), W (T3)	M4	3.5 to 5.5
			
A4075	L1, L2, L3, (-), (+)1, (+)2, B1, B2, U (T1), V (T2), W (T3)	M4	5.5
			
A4110	L1, L2, L3, (-), (+)1, (+)2, B1, B2, U (T1), V (T2), W (T3)	M5	8 to 14
		M6	
A4150	L1, L2, L3, (-), (+)1, (+)2, B1, B2, U (T1), V (T2), W (T3)	M5	8 to 14
		M6	
B4185	L1, L2, L3, L11, L21, L31, (-), (+)1, (+)2, (+)3, U, V, W	M6	14
			
	\square_1, \square_2	M4	0.5 to 5.5
B4220	L1, L2, L3, L11, L21, L31, (-), (+)1, (+)2, (+)3, U, V, W	M6	22
			16
	\square_1, \square_2	M4	0.5 to 5.5
B4300	L1, L2, L3, L11, L21, L31, (-), (+)1, (+)2, (+)3, U, V, W	M8	22
		M6	16
	\square_1, \square_2	M4	0.5 to 5.5
B4370	L1, L2, L3, L11, L21, L31, (-), (+)1, (+)2, (+)3, U, V, W	M8	30
		M6	16
	\square_1, \square_2	M4	0.5 to 5.5

Model 3G3FV/3G3HV -□-CE	Terminal	Terminal screw	Wire thickness (mm ²)
B4450	L1, L2, L3, L11, L21, L31, (-), (+)1, (+)2, (+)3, U, V, W	M8	50
		M6	30
	□ ₁ , □ ₂	M4	0.5 to 5.5
B4550	L1, L2, L3, L11, L21, L31, (-), (+)3, U, V, W	M10	100
		M8	50
	□ ₁ , □ ₂ 200, □ ₂ 400	M4	0.5 to 5.5
B4750	L1, L2, L3, L11, L21, L31, (-), (+)3, U, V, W	M10	60 × 2P
		M8	60
	□ ₁ , □ ₂ 200, □ ₂ 400	M4	0.5 to 5.5
B411K	L1, L2, L3, L11, L21, L31, (-), (+)3, U, V, W	M10	60 × 2P
		M8	60
	□ ₁ , □ ₂ 200, □ ₂ 400	M4	0.5 to 5.5
B416K	L1, L2, L3, L11, L21, L31, (-), (+)3, U, V, W	M12	100 × 2P
		M8	100
	□ ₁ , □ ₂ 200, □ ₂ 400	M4	0.5 to 5.5

Note The wire thickness is set for copper wires at 75°C.

Model 3G3HV-□-CE	Terminal	Terminal screw	Wire thickness (mm ²)
AB004	L, N, (-), (+)1, (+)2, B1, B2, U (T1), V (T2), W (T3)	M4	2 to 5.5
			3.5 to 5.5
AB007	L, N, (-), (+)1, (+)2, B1, B2, U (T1), V (T2), W (T3)	M4	3.5 to 5.5
			
AB015	L, N, (-), (+)1, (+)2, B1, B2, U (T1), V (T2), W (T3)	M4	5.5
			
AB022	L, N, (-), (+)1, (+)2, B1, B2, U (T1), V (T2), W (T3)	M4	8 to 14
			
AB037	L, N, (-), (+)1, (+)2, B1, B2, U (T1), V (T2), W (T3)	M4	14
			

Note The wire thickness is set for copper wires at 75°C.

● Round Solderless Terminals and Tightening Torque

Wire thickness (mm ²)	Terminal screw	Size	Tightening torque (N•m)
0.5	M3.5	1.25 – 3.5	0.8
	M4	1.25 – 4	1.2
0.75	M3.5	1.25 – 3.5	0.8
	M4	1.25 – 4	1.2
1.25	M3.5	1.25 – 3.5	0.8
	M4	1.25 – 4	1.2
2	M3.5	2 – 3.5	0.8
	M4	2 – 4	1.2
	M5	2 – 5	2.0
	M6	2 – 6	2.5
	M8	2 – 8	6.0
3.5/5.5	M4	5.5 – 4	1.2
	M5	5.5 – 5	2.0
	M6	5.5 – 6	2.5
	M8	5.5 – 8	6.0
8	M5	8 – 5	2.0
	M6	8 – 6	2.5
	M8	8 – 8	6.0
14	M6	14 – 6	2.5
	M8	14 – 8	6.0
22	M6	22 – 6	2.5
	M8	22 – 8	6.0
30/38	M8	38 – 8	6.0
50/60	M8	60 – 8	6.0
	M10	60 – 10	10.0
80	M10	80 – 10	10.0
100		100 – 10	10.0
100	M12	100 – 12	14.0
150		150 – 12	14.0
200		200 – 12	14.0
325	M12 × 2	325 – 12	14.0
	M16	325 – 16	25.0

Note Determining Wire Size

Determine the wire size for the main circuit so that line voltage drop is within 2% of the rated voltage.

Line voltage drop is calculated as follows:

$$\text{Line voltage drop (V)} = \sqrt{3} \times \text{wire resistance } (\Omega/\text{km}) \times \text{wire length (m)} \times \text{current (A)} \times 10^{-3}$$

■ **Conformance to EMC Directives**

In order to conform to EMC Directives, the exclusive-use methods are required for noise filter application, cable shielding, and Inverter installation. The following provides an outline of the methods.

The noise filter and the Inverter must be mounted on the same metal plate. The filter should be mounted as close to the Inverter as practical. Keep the cable as short as possible (40 cm max.). The metal plate should be securely grounded. The ground of the noise filter and Inverter must be bonded to the metal plate using as large an area as possible (after peeling off the paint on the Inverter and the metal plate).

For the mains input cable, screened cable is recommended at least within the control panel. The screen of the cable should be connected to a solid ground. For the motor cable, screened cable (20 m max.) must be used and the screen of the motor cable is connected to the ground at both ends by a short connection, using as large an area as possible.

Ground to the supply neutral, which will increase the effect of the noise filter.

The following table and figures provide the noise filter list for the EMC Directives and the installation and wiring of the Inverter and noise filter.

Noise Filter List for EMC Directives

Inverter model 3G3FV/3G3HV	Noise filter (manufactured by Schaffner)			
	Model	Rated current (A)	Weight (kg)	Dimensions (W×D×H) (mm)
A4004-CE	3G3FV-PFS4874-7-07	7	1.1	50×126×255
A4007-CE				
A4015-CE				
A4022-CE	3G3FV-PFS4874-18-07	18	1.7	55×142×305
A4037-CE				
A4055-CE	3G3FV-PFS4874-30-07	30	2.0	60×150×335
A4075-CE				
A4110-CE	3G3FV-PFS4874-42-07	42	3.0	70×185×329
A4150-CE				
B4185-CE	3G3FV-PFS4874-55-07	55	3.3	80×185×329
B4220-CE	3G3FV-PFS4874-75-34	75	4.3	80×220×329
B4300-CE				
B4370-CE	3G3FV-PFS4874-100-35	100	5.7	90×220×379
B4450-CE	3G3FV-PFS4874-130-35	130	8.0	110×240×439
B4550-CE	3G3FV-PFS4874-180-07	180	11	110×240×438
B4750-CE	3G3FV-PFS4874-300-99	300	15	300×564×160
B411K-CE	3G3FV-PFS4874-400-99	400	22	300×564×160
B416K-CE				
AB004-CE	3G3HV-PFS4971-10-07	10	0.7	57.5×156×45.4
AB007-CE	3G3HV-PFS4971-20-07	20	1.0	85.5×119×57.6
AB015-CE				
AB022-CE	3G3HV-PFS4971-40-07	40	3.0	90×246×65
AB037-CE				

- 3G3FV-A4004 to A4150, 3G3HV-A4004 to A4150

Installation of Noise Filter and Inverter

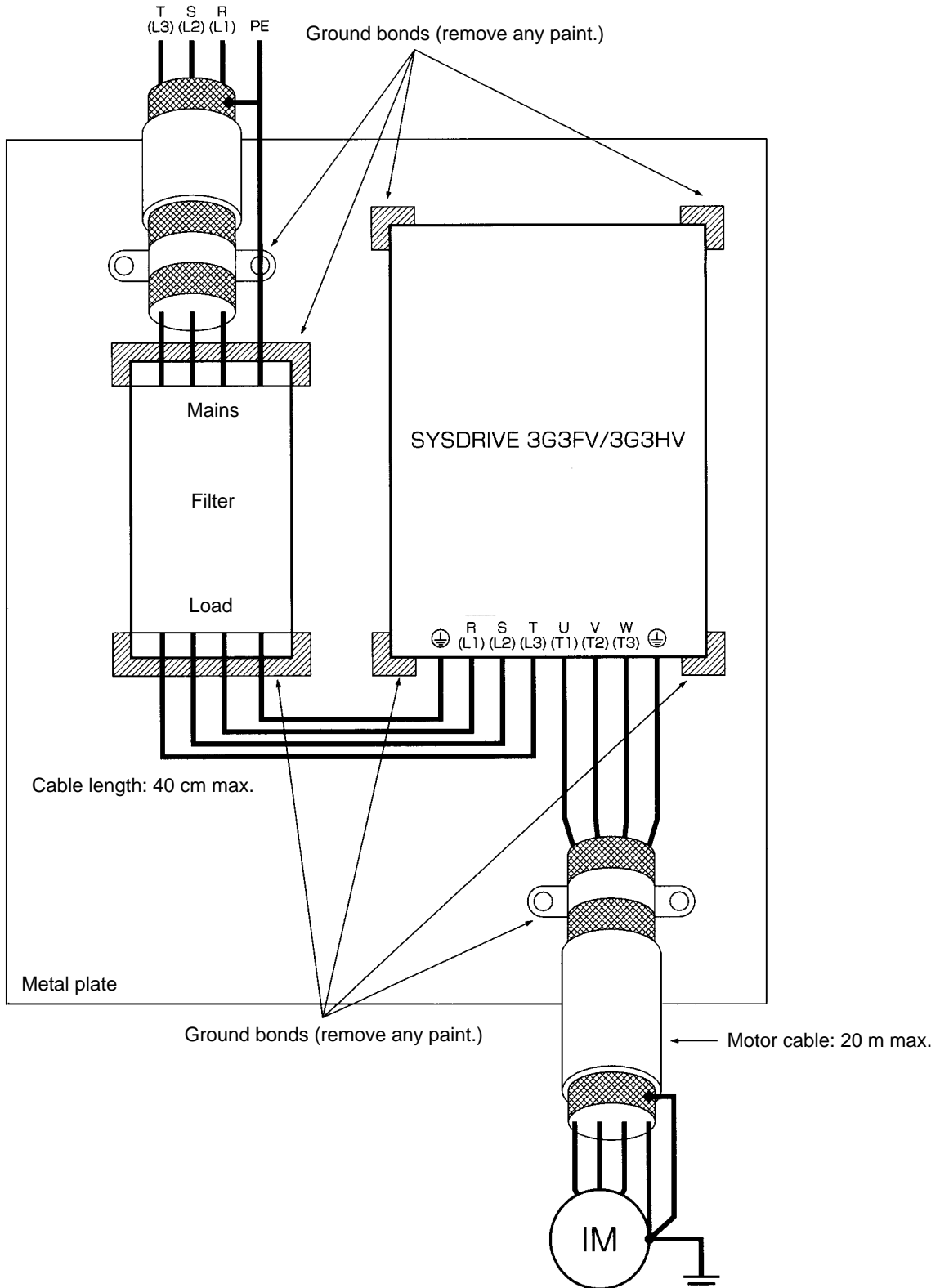

- 3G3FV-B4185 to B416K, 3G3HV-B4185 to B416K

Installation of Noise Filter and Inverter

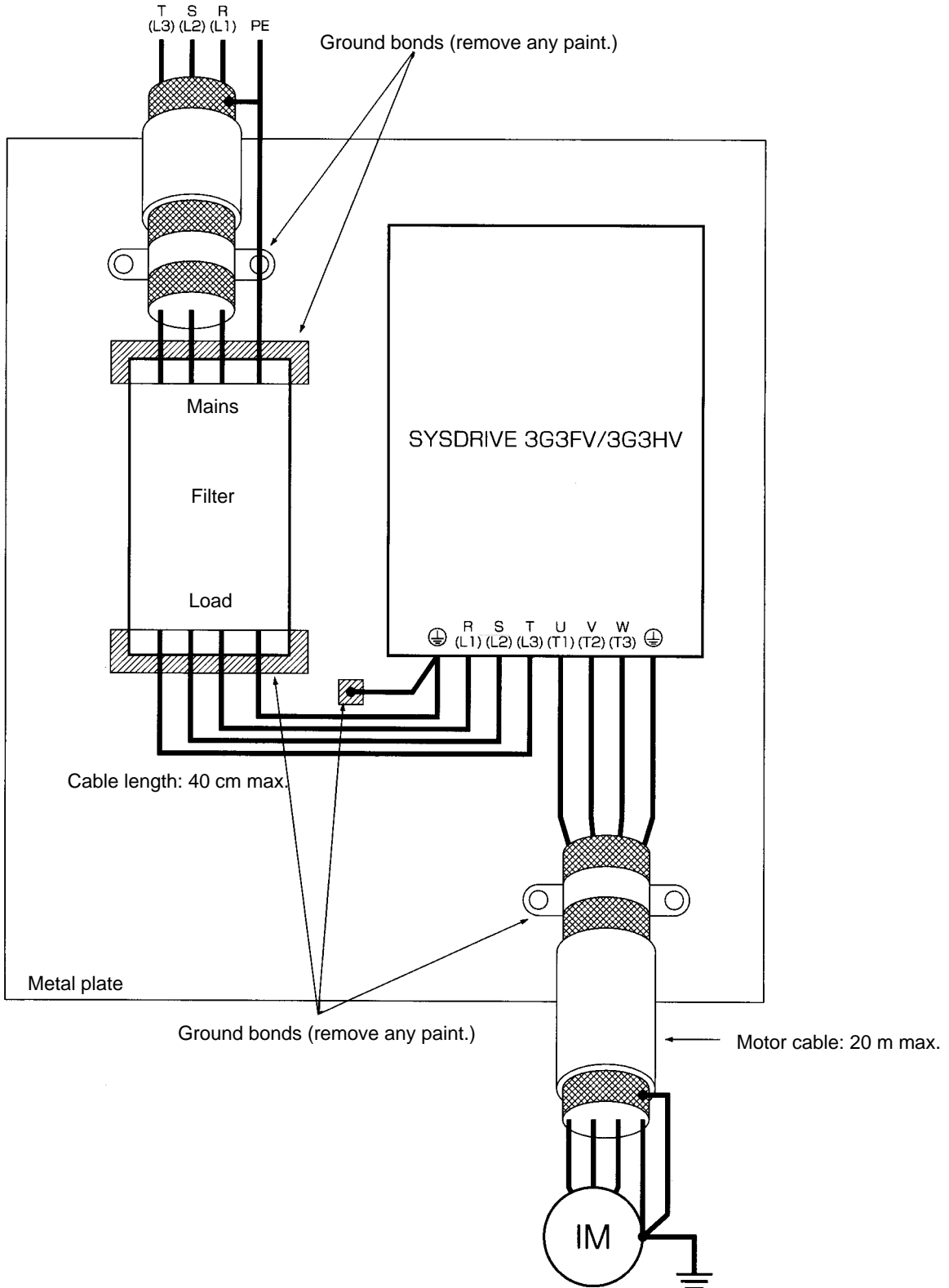

• 3G3HV-AB004 to AB037

Installation of Noise Filter and Inverter

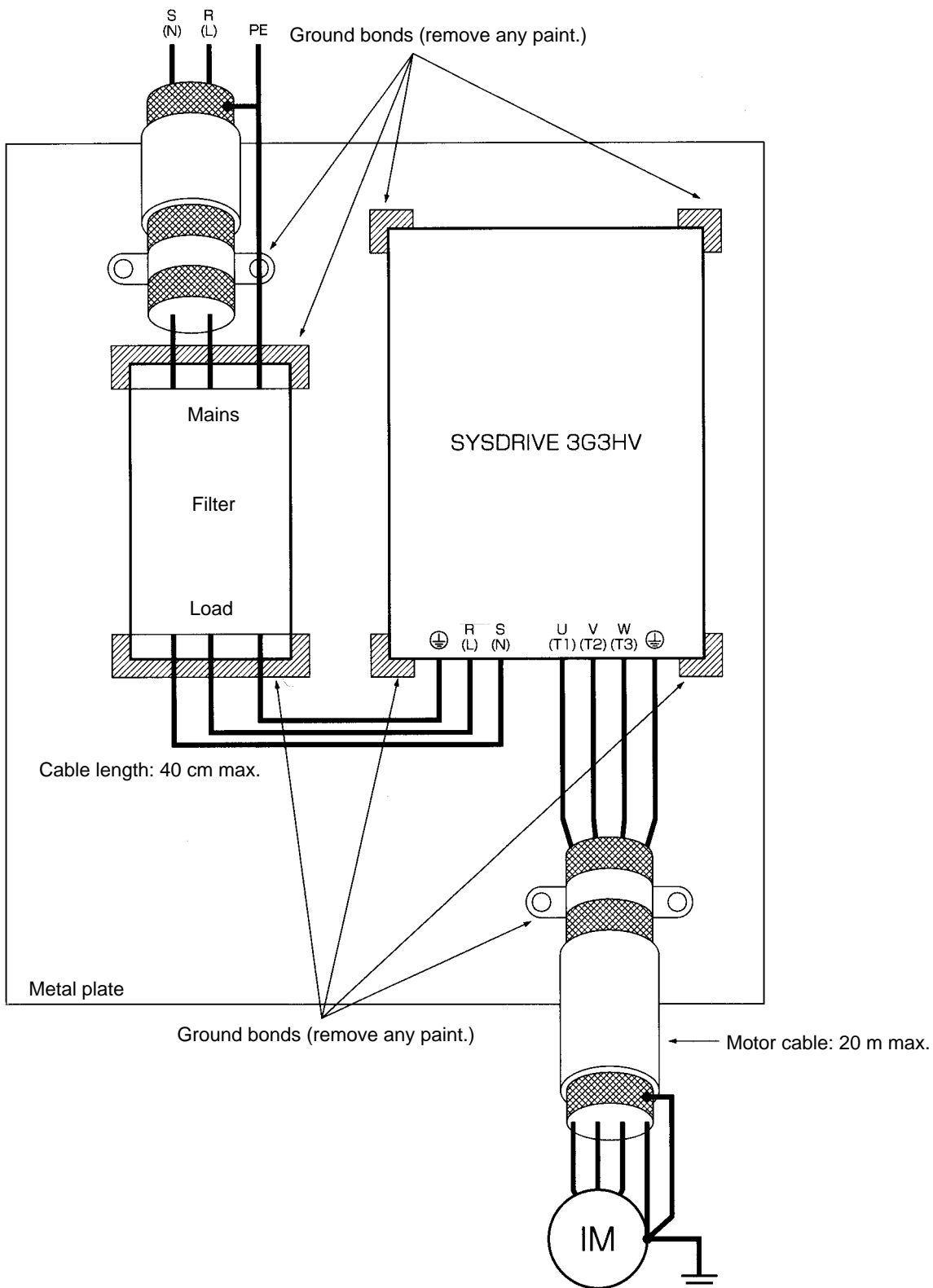

■ Conformance to Low-voltage Directives

An input fuse is not provided with the SYSDRIVE Inverter. Make sure to connect the fuses between the AC main circuit power supply and Inverter input terminals L1, L2 and L3 to protect the input diode or cables. (A fuse is provided in the DC main circuit power supply to protect the output side.)

• Input Diode Protection:

A semiconductor protection fuse is recommended for protecting the input diode when a short-circuit occurs in the Inverter. The following table shows the recommended fuse specifications. Another fuse can be applied if I^2t is smaller than that in the table and rated current is larger than Inverter input current shown in the table.

• Cable Protection:

A general fuse can be applied for cable protection. Observe the local safety regulations for selection. Select the fuse whose rated current is larger than the Inverter input current shown in the following table.

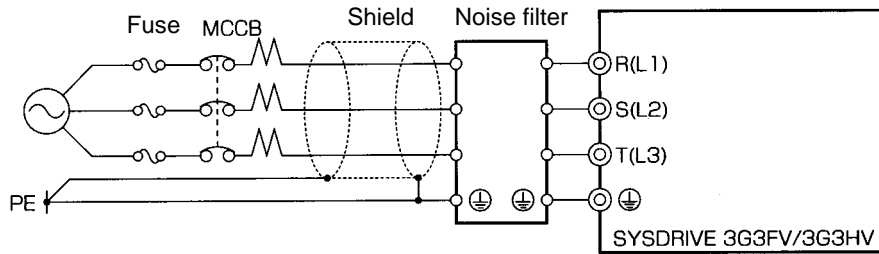

Note Be sure to install an open chassis type Inverter inside a panel.

Input Fuse Selection

Note Both input diodes and cables can be protected by selecting appropriate fuses shown in the following tables.

● **400-V Class**

Inverter		Fuse					
Max. applicable motor output (kW)	Rated input current (A)	Rated current	I ² t max. (A ² s) (at 460 V)	V	Manufacturer	Type	12-pulse input (see note 2)
0.4	2.2	20	140	700	Gould Shawmut	A70P20	---
0.75	4.1	20	140	700		A70P20	---
1.5	5.8	20	140	700		A70P20	---
2.2	7.5	25	220	700		A70P25	---
3.7	9.6	25	220	700		A70P25	---
5.5	16.8	30	320	700		A70P30	---
7.5	26	30	320	700		A70P30	---
11	33	50	880	700		A70P50	---
15	40	60	1,280	700		A70P60	---
18.5	46	70	1,760	700		A70P70	A70P40
22	58	80	2,280	700		A70P80	A70P50
30	72	100	3,600	700		A70P100	A70P60
37	88	125	5,600	700		A70P125	A70P70
45	106	150	8,000	700		A70P150	A70P80
55	141	200	14,400	700		A70P200	A70P100
75	182	225	18,400	700		A70P225	A70P125
110	247	300	32,400	700		A70P300	A70P175
160	330	350	44,000	700	A70P350	A70P200	

Note 1. Select the fuse whose specifications are larger than the rated current and less than I²t when using a fuse other than specified in the table.

Note 2. 12-pulse rectified input is available only for the 3G3HV Series. When using the 12-pulse rectified input, connect the fuses in the table to the power supply terminals (R, S, T, R1, S1, and T1) respectively.

● **200-V Class (Single Phase)**

Inverter		Fuse				
Max. applicable motor output (kW)	Rated input current (A)	Rated current	I ² t max. (A ² s) (at 460 V)	V	Manufacturer	Type
0.4	8.0	20	110	500	Gould Shawmut	A50P20
0.75	15.0	20	110	500		A50P20
1.5	17.6	30	260	500		A50P30
2.2	33.0	40	470	500		A50P40
3.7	44.0	50	720	500		A50P50

Note Select the fuse whose specifications are larger than the rated current and less than I²t when using a fuse other than specified in the table.

■ Wiring on the Input Side of Main Circuit

● Installing a Molded-case Circuit Breaker

Provide fuses recommended for each Inverter between the power supply and the power input terminals (L1, L2, and L3). It is recommended that a molded case circuit breaker (MCCB) that matches the Inverter be provided between the power supply and the input terminals to facilitate easy operation and maintenance.

- Choose an MCCB with a capacity of 1.5 to 2 times the Inverter’s rated current.
- For the MCCB’s time characteristics, be sure to consider the Inverter’s overload protection (one minute at 150% of the rated output current).
- Since diodes and cables of individual Inverters need not be protected, if the MCCB is to be used in common among multiple Inverters or other devices, set up a sequence such that the power supply will be turned off by a fault output, as shown in the following diagram.

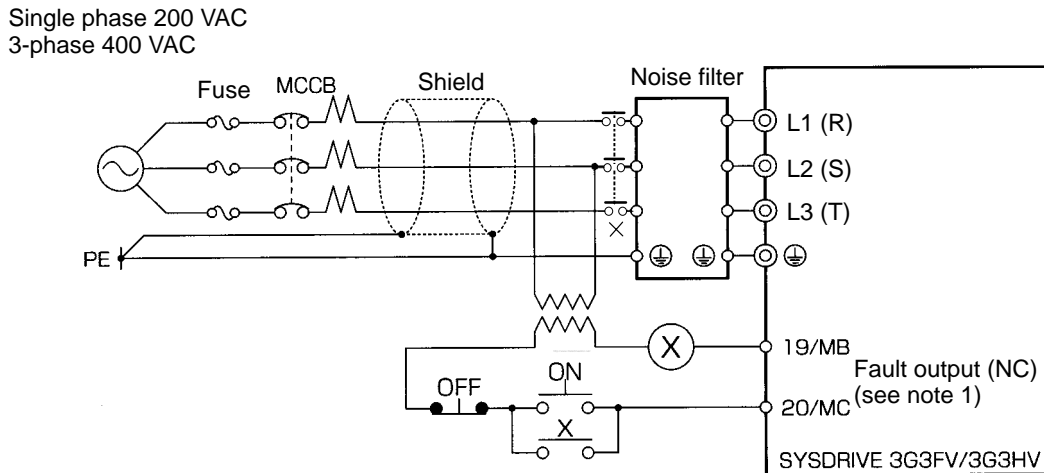

Note 1. Terminals 19 and 20 are terminal numbers for the 3G3FV, and MB and MC are terminal numbers for the 3G3HV. Since the terminals MB and MC are multi-functional outputs, set to “Error (n040=0).”

Note 2. Connect a 400-/200-V transformer for the 2,400-V-class model.

● Installing a Ground Fault Interrupter

Inverter outputs use high-speed switching, so high-frequency leakage current is generated. In general, a leakage current of approximately 100 mA will occur for each Inverter (when the power cable is 1 m), and approximately 5 mA for each additional meter of power cable. Therefore, at the power supply input area, use a special-purpose breaker for Inverters, which detects only the leakage current in the frequency range that is hazardous to humans and excludes high-frequency leakage current.

Countermeasures taken for the EMC tend to increase the leakage current, therefore careful attention must be paid in selecting a breaker.

- For the special-purpose breaker for Inverters, choose a ground fault interrupter with a sensitivity amperage of at least 10 mA per Inverter.
- When using a general leakage breaker, choose a ground fault interrupter with a sensitivity amperage of 200 mA or more per Inverter and with an operating time of 0.1 s or more.

● Installing a Magnetic Contactor

If the power supply for the main circuit is to be shut off because of the sequence, a magnetic contactor can be used instead of a molded-case circuit breaker.

When a magnetic contactor is installed on the primary side of the main circuit to forcibly stop a load, however, the regenerative braking does not work and the load coasts to a stop.

- A load can be started and stopped by opening and closing the magnetic contactor on the primary side. Frequently opening and closing the magnetic contactor, however, may cause the Inverter to break down.
- When the Inverter is operated with the Digital Operator, automatic operation cannot be performed after recovery from a power interruption.
- If the Braking Resistor Unit is to be used, program the sequence so that the magnetic contactor is turned off by the contact of the Unit's thermal relay.

● Connecting Input Power Supply to the Terminal Block

Input power supply can be connected to any terminal on the terminal block because the phase sequence of input power supply is irrelevant to the phase sequence (L1, L2, and L3).

● Installing an AC Reactor

If the Inverter is connected to a large-capacity power transformer (600 kW or more) or the phase advance capacitor is switched, an excessive peak current may flow through the input power circuit, causing the converter unit to break down. To prevent this, install an optional AC reactor on the input side of the Inverter. This also improves the power factor on the power supply side.

● Installing a Surge Absorber

Always use a surge absorber or diode for the inductive loads near the Inverter. These inductive loads include magnetic contactors, electromagnetic relays, solenoid valves, solenoids, and magnetic brakes.

● Wiring the Power Terminal of the Inverter with 18.5- to 160-kW Output

- For 400-V class, 18.5 to 45 kW, connect the r and s terminals to the L1 (R) and L2 (S) terminals respectively. (These are shorted by short bars for shipping.)
- For 400-V class, 55 to 160 kW, connect the r and s 400 terminals to the L1 (R) and L2 (S) terminals respectively. (These are shorted by short bars for shipping.)

● Wiring the Power Terminal of the Inverter with 3G3HV Series with 18.5- to 160-kW Output

Refer to the following to wire terminals R, S, T, R1, S1, and T1.

● Three-phase Power Input

Make sure that terminals R and R1, S and S1, and T and T1 are short-circuited before supplying power to the Inverter. These terminals are short-circuited with short bars before shipping.

The Inverter may break down if only terminals R, S, and T or terminals R1, S1, and T1 are supplied with power.

● 12-pulse Rectification

Terminals R and R1, S and S1, and T and T1 are short-circuited with short bars before shipping. Be sure to remove the short bars when using 12-pulse rectification, otherwise the Inverter will break down.

■ **Wiring on the Output Side of Main Circuit**

● **Connecting the Terminal Block to the Load**

Connect output terminals T1 (U), T2 (V), and T3 (W) to motor lead wires T1 (U), T2 (V), and T3 (W), respectively. Check that the motor rotates forward with the forward command. Switch over any two of the output terminals to each other and reconnect if the motor rotates in reverse with the forward command.

● **Never Connect a Power Supply to Output Terminals**

Never connect a power supply to output terminals T1 (U), T2 (V), and T3 (W). If voltage is applied to the output terminals, the internal circuit of the Inverter will be damaged.

● **Never Short or Ground Output Terminals**

If the output terminals are touched with bare hands or the output wires come into contact with the Inverter casing, an electric shock or grounding will occur. This is extremely hazardous. Also, be careful not to short the output wires.

● **Do Not Use a Phase Advancing Capacitor or Noise Filter**

Never to connect a phase advance capacitor or LC/RC noise filter to the output circuit. Doing so may result in damage to the Inverter or cause other parts to burn.

● **Do Not Use an Electromagnetic Switch or Magnetic Contactor**

Do not connect an electromagnetic switch or magnetic contactor to the output circuit. If a load is connected to the Inverter during running, an inrush current will actuate the overcurrent protective circuit in the Inverter.

● **Installing a Thermal Relay**

This Inverter has an electronic thermal protection function to protect the motor from overheating. If, however, more than one motor is operated with one Inverter or multi-polar motor is used, always install a thermal relay (THR) between the Inverter and the motor and set n033 to 0 (no thermal protection). In this case, program the sequence so that the magnetic contactor on the input side of the main circuit is turned off by the contact of the thermal relay.

● **Installing a Noise Filter on Output Side**

Connect a noise filter to the output side of the Inverter to reduce radio noise and induction noise.

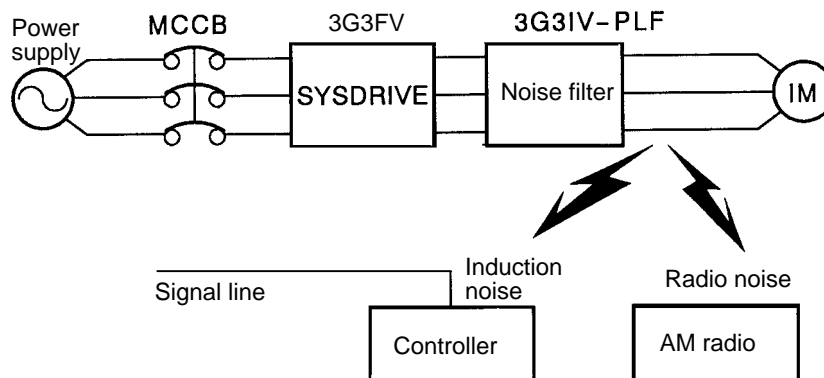

Induction Noise: Electromagnetic induction generates noise on the signal line, causing the controller to malfunction.

Radio Noise: Electromagnetic waves from the Inverter and cables cause the broadcasting radio receiver to make noise.

● Cable Length between Inverter and Motor

If the cable between the Inverter and the motor is long, the high-frequency leakage current will increase, causing the Inverter output current to increase as well. This may affect peripheral devices. To prevent this, adjust the carrier frequency (set in C06-01 to C06-03 or n050) as shown in the table below. (For details, refer to the parameter settings.)

Model	Cable length	20 m max.	40 m max.	More than 40 m
	Carrier frequency	15 kHz max.	10 kHz max.	5 kHz max.
3G3FV	(Set value: C06-01)	(15.0)	(10.0)	(5.0)
	(Set value: C06-02)	(15.0)	(10.0)	(5.0)
	(Set value: C06-02)	(0)	(0)	(0)
3G3HV	(Set value: n050)	(6)	(4)	(2)

■ Ground Wiring

- Connect the ground terminal to the supply neutral (neutral point of the input power supply).
- Always use the ground terminal of the 200-V Inverter with a ground resistance of less than 100 Ω and that of the 400-V Inverter with a ground resistance of less than 10 Ω.
- Do not share the ground wire with other devices such as welding machines or power tools.
- Connect the ground terminal before connecting any other terminal. When removing the wiring, remove the ground wire last.
- Always use a ground wire that complies with technical standards on electrical equipment and minimize the length of the ground wire.
Leakage current flows through the Inverter. Therefore, if the distance between the ground electrode and the ground terminal of the Inverter will become unstable.
- When using more than one Inverter, be careful not to loop the ground wire.

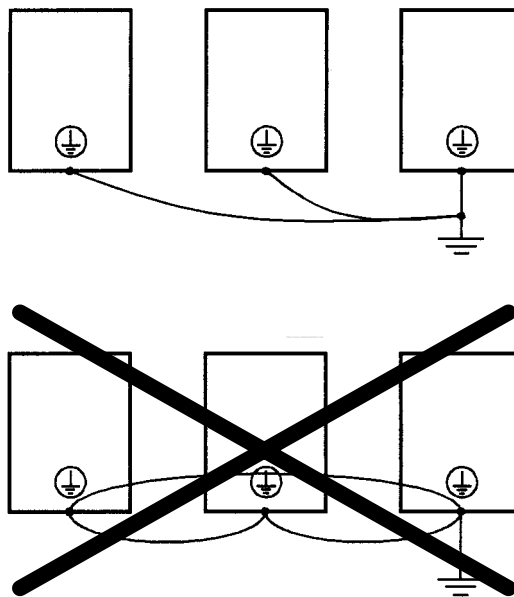

■ Countermeasures against Harmonics

With the continuing development of electronics, the generation of harmonics from industrial machines has been causing problems recently. Refer to the following for the definition of harmonics (i.e., harmonic currents with voltages) and countermeasures against the generation of harmonics from the Inverter.

● Harmonics (Harmonic Currents with Voltages)

● Definition

Harmonics consist of electric power produced from AC power and alternating at frequencies that are integral multiples of the frequency of the AC power.

The following are the harmonic frequencies of a 60- or 50-Hz commercial power supply.

Second harmonic: 120 (100) Hz

Third harmonic: 180 (150) Hz

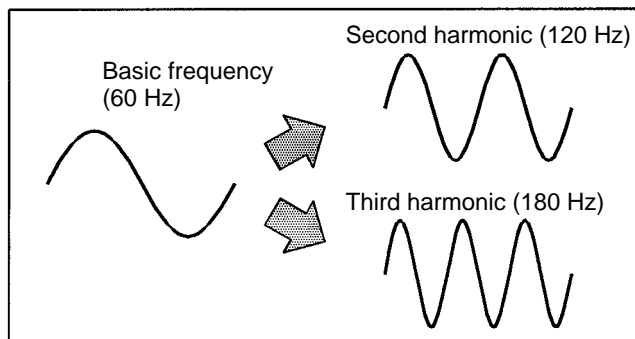

● Problems Caused by Harmonics Generation

The waveform of the commercial power supply will be distorted if the commercial power supply contains excessive harmonics.

Machines with such a commercial power supply will malfunction or generate excessive heat.

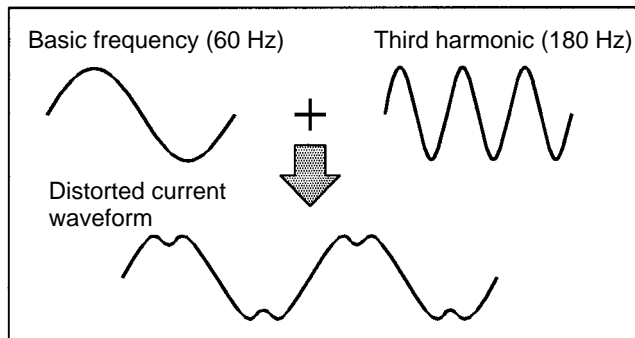

● Causes of Harmonics Generation

● Usually, electric machines have built-in circuitry that converts commercial AC power supply into DC power. Such AC power, however, contains harmonics due to the difference in current flow between AC and DC.

● Obtaining DC from AC using Rectifiers and Capacitors

DC voltage is obtained by converting AC voltage into a pulsating one-side voltage with rectifiers and smoothing the pulsating one-side voltage with capacitors. Such AC current, however, contains harmonics.

• **Inverter**

The Inverter as well as normal electric machines has an input current containing harmonics because the Inverter converts AC into DC.

The output current of the Inverter is comparatively high. Therefore, the ratio of harmonics in the output current of the Inverter is higher than that of any other electric machine.

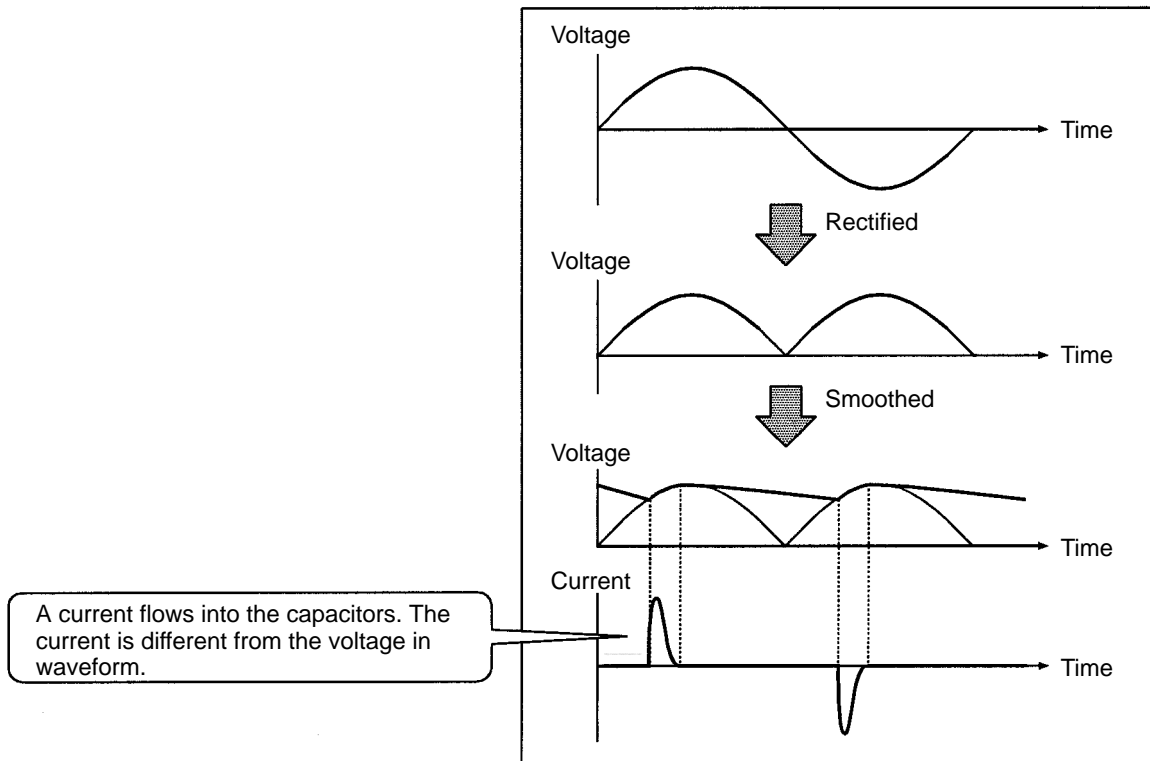

• **Countermeasures with Reactors against Harmonics Generation**

• **DC/AC Reactors**

The DC reactor and AC reactor suppress harmonics and currents that change suddenly and greatly. The DC reactor suppresses harmonics better than the AC reactor. The DC reactor used with the AC reactor suppresses harmonics more effectively.

The input power factor of the Inverter is improved by suppressing the harmonics in the input current of the Inverter.

Note 18.5- to 160-kW models have a built-in DC reactor.

• **Connection**

Connect the DC reactor to the internal DC power supply of the Inverter after shutting off the power supply to the Inverter and making sure that the charge indicator of the Inverter turns off.

! WARNING Do not touch the internal circuitry of the Inverter in operation, otherwise an electric shock or a burn injury may occur.

• **Wiring Method**
With DC Reactor

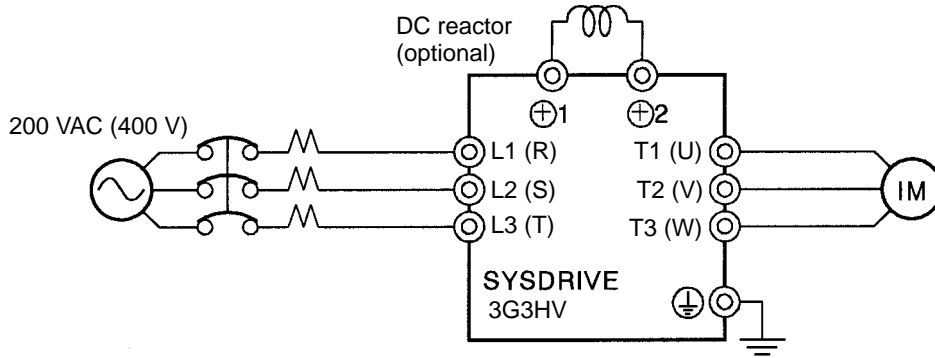

Note Be sure to remove the short bar on terminals +1 and +2 before connecting the DC reactor.

With DC and AC Reactors

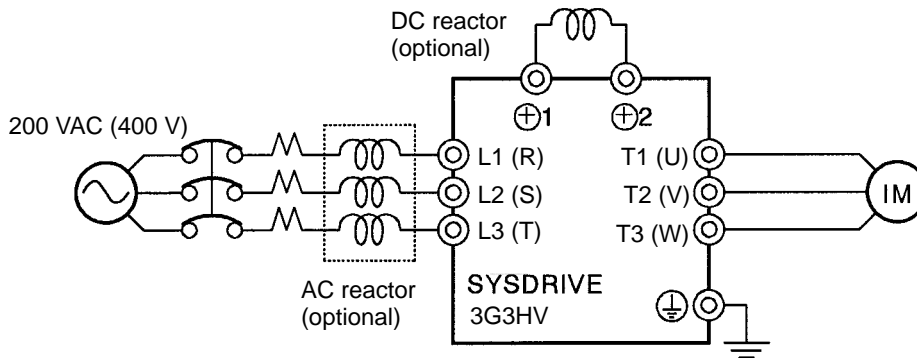

Note Be sure to remove the short bar on terminals +1 and +2 before connecting the DC reactor.

• **Reactor Effects**

Harmonics are effectively suppressed when the DC reactor is used with the AC reactor as shown in the following table.

Harmonic suppression method (3-phase input)	Harmonic generation rate (%)							
	5th harmonic	7th harmonic	11th harmonic	13th harmonic	17th harmonic	19th harmonic	23th harmonic	25th harmonic
No reactor	65	41	8.5	7.7	4.3	3.1	2.6	1.8
AC reactor	38	14.5	7.4	3.4	3.2	1.9	1.7	1.3
DC reactor	30	13	8.4	5	4.7	3.2	3.0	2.2
DC and AC reactors	28	9.1	7.2	4.1	3.2	2.4	1.6	1.4

● Countermeasures with 12-pulse Rectification against Harmonics Generation (Only for 3G3HV Models Larger than 18.5 kW)

● 12-pulse Rectification

The 3G3HV-series Inverter with an output of 18.5 to 160 kW can employ 12-pulse rectification, which suppresses harmonics better than reactors. The 3G3HV-series Inverter with an output of 15 kW or less cannot employ 12-pulse rectification.

● Wiring Method

1. Terminals L1 (R) and L11 (R1), L2 (S) and L21 (S1), and L3 (T) and L31 (T1) are short-circuited with short bars before shipping. Be sure to remove the short bars when employing 12-pulse rectification, otherwise the Inverter will break down.
2. Do not ground the secondary winding side of the transformer, otherwise the Inverter may break down.

With Input Transformer for 12-pulse Rectification

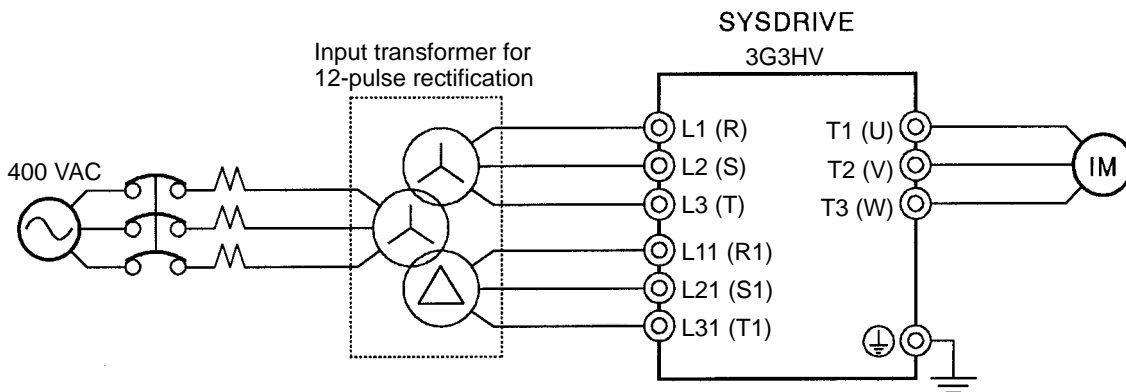

With Standard Transformers for 12-pulse Rectification

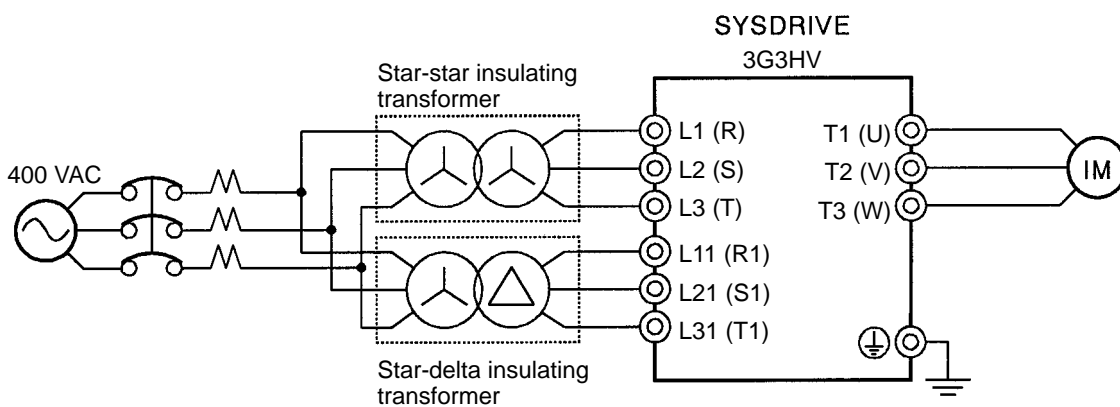

Note Use insulating transformers.

• **Input Transformers for 12-pulse Rectification**

Refer to the following table to select the input transformer for 12-pulse rectification. Refer to the minimum currents on the secondary winding side in the table when selecting two standard transformers used in combination for 12-pulse rectification.

Inverter model 3G3HV-	Input voltage (V)	Minimum current on the primary winding side (A)	Minimum current on the secondary winding side (A)
B4185	I/O voltage ratio: 1:1 380 to 460 V ±10%/ 380 to 460 V±10% at 50/60 Hz	52	26
B4220		66	33
B4300		82	41
B4370		100	50
B4450		120	60
B4550		180	80

• **12-pulse Rectification Effect**

Harmonics are suppressed effectively with 12-pulse rectification as shown in the following table.

Harmonic suppression method	Harmonic generation rate (%)							
	5th harmonic	7th harmonic	11th harmonic	13th harmonic	17th harmonic	19th harmonic	23th harmonic	25th harmonic
No reactor	65	41	8.5	7.7	4.3	3.1	2.6	1.8
12-pulse rectification	5.43	5.28	5.40	5.96	0.69	0.19	1.49	1.18

■ **Connecting the Braking Resistor**

- Connect the braking resistor as shown in the following diagram.
- When using a Braking Resistor for the 3G3FV, set L8-01 to “1” (i.e., overheating protection of the braking resistor) and set L3-04 to “0” (i.e., no decelerating stall prevention).
- For the 3G3HV, set n079 (braking resistor overheating protection) to “1” and n070 (no decelerating stall prevention) to “0.”

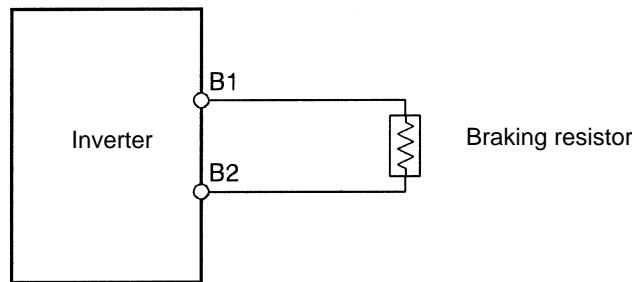

Caution

The braking resistor’s connection terminals are B1 and B2. Do not connect any other terminals. Connecting any terminals other than B1 or B2 can cause the resistor to overheat, resulting in damage to the equipment.

■ Connecting the Braking Resistor Unit and Braking Unit

- Connect the Braking Resistor Unit and Braking Unit to the Inverter as shown in the following diagrams.
- For the 3G3FV, set L8-01 to “0” (i.e., no overheating protection of the braking resistor) and L3-04 to “0” (i.e., no decelerating stall prevention) before using the Inverter with the Braking Resistor Unit connected.
- For the 3G3HV, set n079 to “1” and n070 to “0.”

Note 1. Set L8-01 to “1” (n079 to “1”) when operating the Inverter with the braking resistor without thermal relay trip contacts.

Note 2. The Braking Resistor Unit cannot be used and the deceleration time cannot be shortened by the Inverter if L3-04 (n070) is set to “1” (i.e., decelerating stall prevention).

- To prevent the Unit from overheating, make a power supply sequence as shown below or connect the thermal relay trip output of the Unit to the external fault input terminal of the Inverter to interrupt the running of the Inverter.

● 200-V Class with 0.4- to 3.7-kW Output and 400-V Class with 0.4- to 15-kW Output

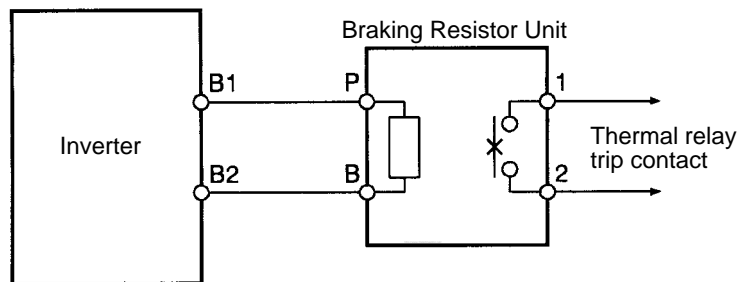

● 400-V Class with 18.5-or-more Output

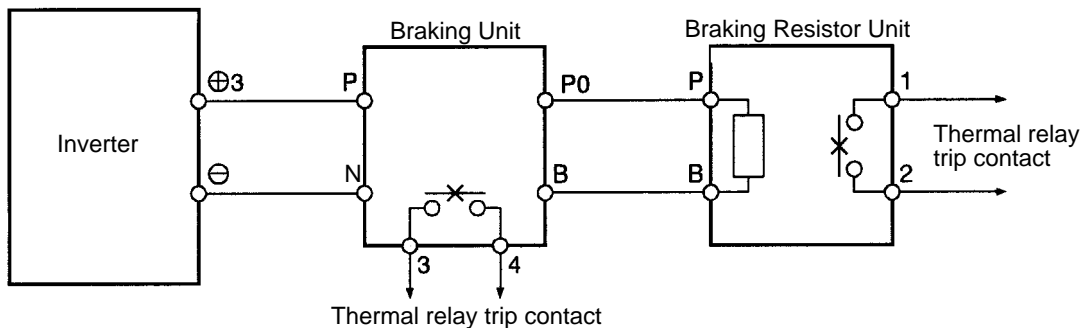

Note Braking Units or Braking Resistor Units cannot be connected to a 3G3HV model with a capacity of 18.5 kW or larger.

• Connecting Braking Units in Parallel

When connecting two or more Braking Units in parallel, use the wiring and connectors shown in the following diagram. There are connectors for selecting whether each Braking Unit is to be a Master or Slave. Select “Master” for the first Braking Unit only; select “Slave” for all other Braking Units (i.e., from the second Unit onwards).

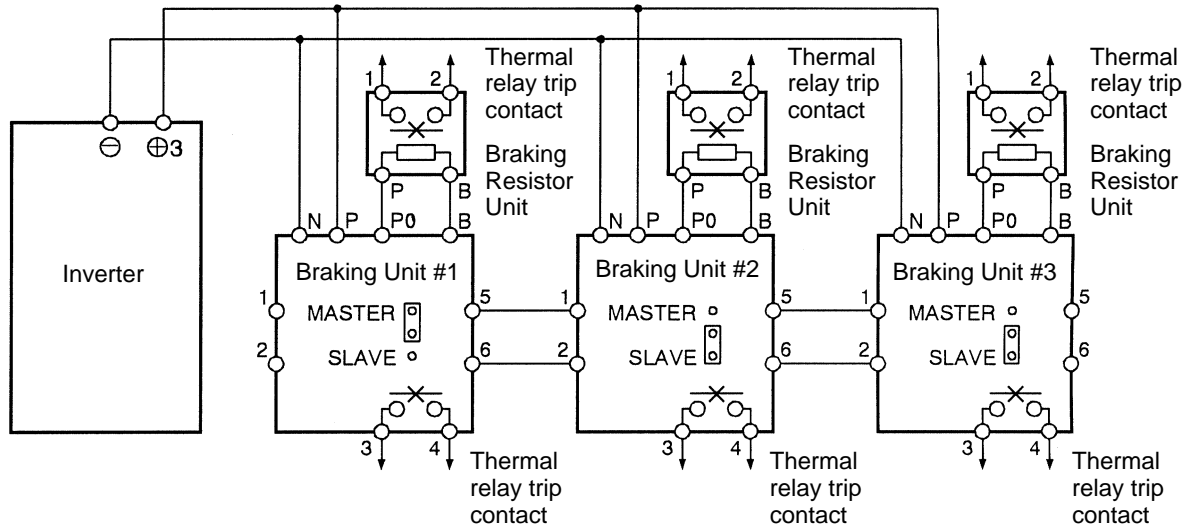

• Power Supply Sequence

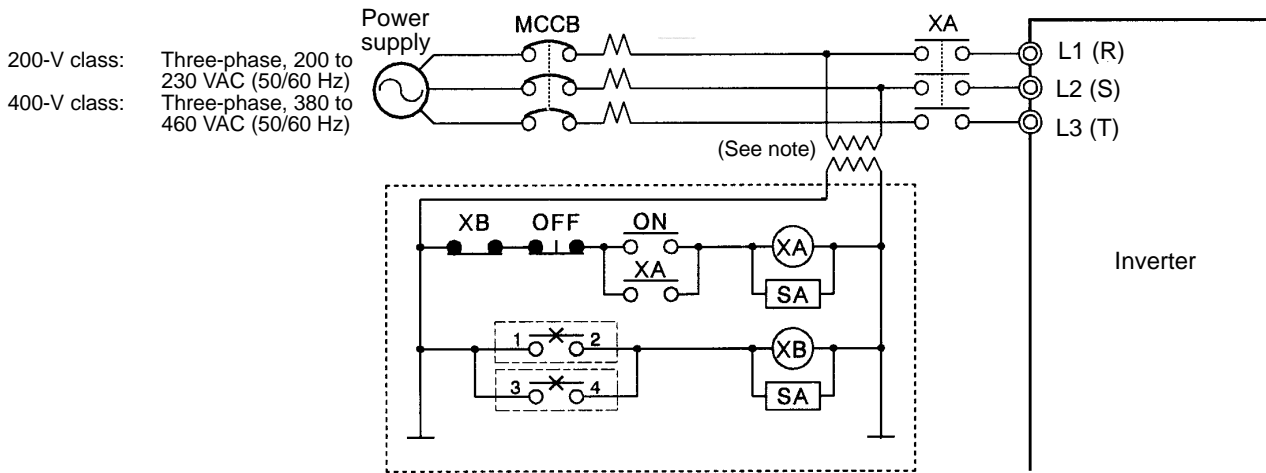

Note Use a transformer with 200- and 400-V outputs for the power supply of the 400-V Inverter.

2-2-5 Wiring Control Circuit Terminals

A control signal line must be 50 m maximum and separated from power lines. The frequency reference must be input to the Inverter through twisted-pair wires.

■ Wire Size and Round Solderless Terminals

Use thick wires to prevent voltage drops if the wires are long.

● Wires for All Inverter Models

Terminal	Terminal screw	Wire thickness (mm ²)	Type
3G3FV 1 to 43 3G3HV S1, S2, S3, S4, S5, S6, SC, FV, FI, FS, FC, AM, AC, M1, M2, MA, MB, MC	---	Stranded wire: 0.5 to 1.25 Single wire: 0.5 to 1.25	Shielded, twisted-pair wire Shielded, polyethylene-covered, vinyl sheath cable
E (G)	M3.5	0.5 to 2	

● Solderless Terminals for Control Circuit Terminals

The use of solderless terminals for the control circuit terminals is recommended because solderless terminals are easy to connect securely.

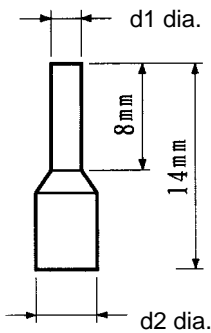

Wire thickness	Model	d1	d2	Manufacturer
0.5 mm ²	A1 0.5-8WH	1.00	2.60	Phoenix Contact
0.75 mm ²	A1 0.75-8GY	1.20	2.80	
1 mm ²	A1 1-8RD	1.40	3.00	
1.5 mm ²	A1 1.5-8BK	1.70	3.50	

Note Do not solder wires with the control circuit terminals if wires are used instead of solderless terminals. Wires may not contact well with the control circuit terminals or the wires may be disconnected from the control circuit terminals due to vibration if the wires are soldered.

● Round Solderless Terminals for Ground Terminal

Wire thickness (mm ²)	Terminal screw	Size
0.5	M3.5	1.25 to 3.5
0.75		1.25 to 3.5
1.25		1.25 to 3.5
2		2 to 3.5

■ Wiring Control Circuit Terminals

● Wiring Method

1. Loosen the terminal screws with a thin-slotted screwdriver.
2. Insert the wires from underneath the terminal block.
3. Tighten the terminal screws firmly.

Note 1. Always separate the control signal line from the main circuit cables and other power cables.

Note 2. Do not solder the wires to the control circuit terminals. The wires may not contact well with the control circuit terminals if the wires are soldered.

Note 3. The end of each wire connected to the control circuit terminals must be stripped for approximately 7 mm.

Note 4. Use a shielded wire for the ground terminal.

Note 5. Insulate the shield with tape so that the shield will not touch any signal line or device.

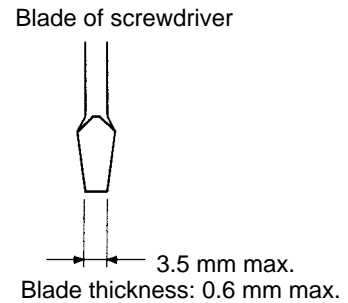
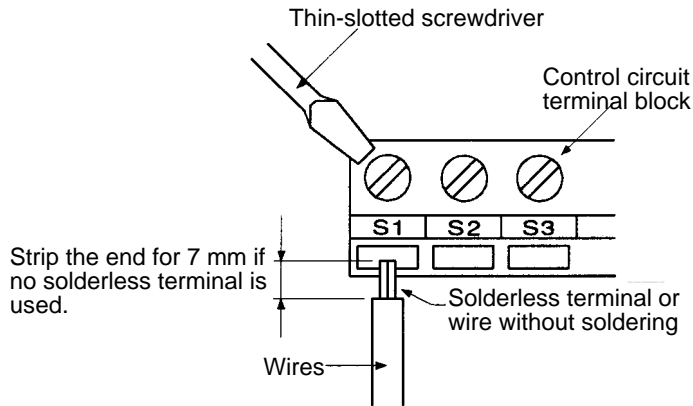

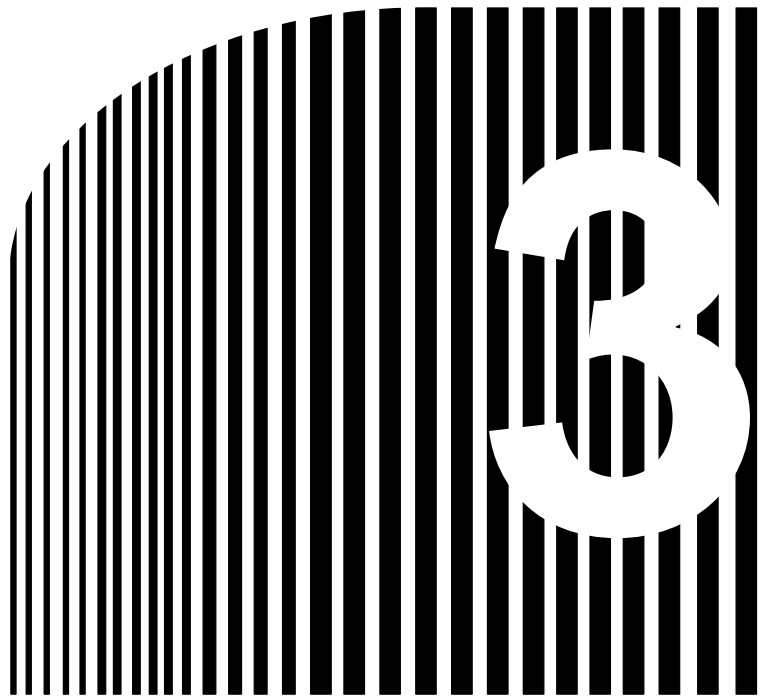

Chapter 3

• Specifications •

- 3-1 Inverter Specifications
- 3-2 Input Noise Filter Specification

3-1 Inverter Specifications

General Specifications for 3G3FV Inverters

Model number 3G3FV-□-CE	A4004	A4007	A4015	A4022	A4037	A4055	A4075	A4110	A4150	B4185	B4220	B4300	B4370	B4450	B4550	B4750	B411K	B416K
Max. applicable motor capacity (kW)	0.4	0.75	1.5	2.2	3.7	5.5	7.5	11	15	18.5	22	30	37	45	55	75	110	160
Output characteristics																		
Rated output capacity (kVA)	1.4	2.6	3.7	4.7	6.1	11	14	21	26	31	37	50	61	73	98	130	170	230
Rated output current (A)	1.8	3.4	4.8	6.2	8.0	14	18	27	34	41	48	65	80	96	128	165	224	302
Max. output voltage (V)	3-phase, 380 to 460 VAC (Corresponds to input voltage.)																	
Max. output frequency (Hz)	400 Hz (Set by parameter constant.)																	
Power supply characteristics																		
Rated voltage (V) Rated frequency (Hz)	3-phase, 380 to 460 VAC, 50/60 Hz																	
Allowable voltage fluctuation	-15% to 10%																	
Allowable frequency fluctuation	±5%																	
Power consumption (kW)	0.06	0.09	0.11	0.13	0.15	0.22	0.36	0.46	0.57	0.66	0.88	1.1	1.3	1.4	1.9	2.4	3.1	4.2
Approximate weight (kg)	3.0	3.0	4.0	4.5	4.5	6.0	6.0	11	11	29	31	44	44	44	81	82	135	145

Control Characteristics

Model number 3G3FV-□-CE	A4004	A4007	A4015	A4022	A4037	A4055	A4075	A4110	A4150	B4185	B4220	B4300	B4370	B4450	B4550	B4750	B411K	B416K
Power supply harmonic countermeasures	DC reactor (option) connection possible.										DC reactor built in							
Control method	Sine wave PWM (high-carrier frequency control)																	
Carrier frequency	0.4 to 15 kHz (2.0 to 15 kHz in vector control)												0.4 to 10 kHz (2.0 to 10 kHz in vector control)					
Speed control range	1:100 (1:1000 with PG)																	
Speed control precision	±0.2% (±0.02% with PG)																	
Speed control response	5 Hz (30 Hz with PG)																	
Torque characteristics	150% at 1 Hz (150% at 0 rpm with PG). A torque limit function is incorporated.																	
Torque control precision	±5% (with PG)																	
Frequency control range	0.1 to 400 Hz																	
Frequency precision (temperature characteristics)	Digital commands: ±0.01% (-10° to 40°C) Analog commands: ±0.1% (25°±10°C)																	
Frequency setting resolution	Digital commands: 0.01 Hz (Less than 100 Hz) Analog commands: 0.03 Hz/60 Hz (11 bits + sign)																	
Output frequency resolution	0.001 Hz																	
Overload capacity	150% of rated current for one minute																	
Frequency setting signal	0 to ±10 VDC, 0 to 10 VDC (20 kΩ) voltage input or 4 to 20 mA (250 Ω) current input																	
Acceleration/Deceleration time	0.01 to 6000.0 s (4 selectable combinations of independent acceleration and deceleration settings)																	
Braking torque	Approximately 20% (Increment possible with an external braking resistor.)																	
Voltage/frequency characteristics	Select vector control, one from 15 types of fixed V/f patterns, or set a user V/f pattern.																	

Protective Functions

Model number 3G3FV-□-CE	A4004	A4007	A4015	A4022	A4037	A4055	A4075	A4110	A4150	B4185	B4220	B4300	B4370	B4450	B4550	B4750	B411K	B416K
Motor protection	Protection by electronic thermal.																	
Instantaneous overcurrent protection	Stops at approx. 200% of rated output current.																	
Overload protection	Stops in one minute at approx. 150% of rated output current.																	
Overvoltage protection	Stops when main-circuit DC voltage is approx. 820 V.																	
Undervoltage protection	Stops when main-circuit DC voltage is approx. 380 V.																	
Momentary power interruption compensation (selection)	Stops for 15 ms or more. By selecting the momentary power interruption mode, operation can be continued if power is restored within 2 s.																	
Cooling fin overheating	Protection by thermistor.																	
Grounding protection	Protection by electronic circuits.																	
Charge indicator (internal LED)	Lit when the main circuit DC voltage is approx. 50 V or more.																	

Environment

Model number 3G3FV-□-CE	A4004	A4007	A4015	A4022	A4037	A4055	A4075	A4110	A4150	B4185	B4220	B4300	B4370	B4450	B4550	B4750	B411K	B416K
Location	Indoors (no corrosive gas, oil spray, metallic dust, etc.)																	
Ambient operating temperature	-10° to 45°C (NEMA1 type: -10° to 40°C)									-10° to 45°C (Open-chassis type)								
Ambient operating humidity	90% RH max. (with no condensation)																	
Storage temperature	-20° to 60°C																	
Altitude	1,000 m max.																	
Insulation resistance	5 MΩ min. (Do not carry out the insulation resistance test or withstand voltage test.)																	
Vibration withstand	Vibration frequency less than 20 Hz, 9.8 m/s ² {1G} max.; 20 to 50 Hz, 2 m/s ² {0.2G} max																	
Protective structure	Both NEMA1 type: IP20 and open-chassis type: IP00									Open-chassis type: IP00								

General Specifications for 3G3HV Inverters

● 200-V Class

Model 3G3HV-□-CE	AB004	AB007	AB015	AB022	AB037
Maximum applicable motor capacity (kW)	0.4	0.75	1.5	2.2	3.7
Output characteristics					
Rated output capacity (kVA)	1.2	2.3	3.0	4.2	6.7
Rated output current (A)	3.2	6	8	11	17.5
Maximum output voltage (V)	3-phase, 200 to 230 VAC (Corresponds to input voltage.)				
Maximum output frequency (Hz)	400 Hz (Set by parameter constant.)				
Power supply characteristics					
Rated voltage (V) Rated frequency (Hz)	Single-phase, 200 to 230 VAC, 50/60 Hz				
Allowable voltage fluctuation	-15% to 10%				
Allowable frequency fluctuation	±5%				
Heat generated (kW)	0.07	0.09	0.12	0.14	0.22
Weight (kg)	Approx. 3	Approx. 4.5	Approx. 4.5	Approx. 6	Approx. 6

● 400-V Class

Model 3G3HV-□-CE	A4004	A4007	A4015	A4022	A4037	A4055	A4075	A4110	A4150	B4185	B4220	B4300	B4370	B4450	B4550	B4750	B411K	B416K
Maximum applicable motor capacity (kW)	0.4	0.75	1.5	2.2	3.7	5.5	7.5	11	15	18.5	22	30	37	45	55	75	110	160
Output characteristics																		
Rated output capacity (kVA)	1.4	2.6	3.7	4.7	6.1	11	14	21	26	31	40	50	61	73	98	130	170	230
Rated output current (A)	1.8	3.4	4.8	6.2	8	14	18	27	34	41	52	65	80	96	128	165	224	302
Maximum output voltage (V)	3-phase, 380 to 460 VAC (Corresponds to input voltage.)																	
Maximum output frequency (Hz)	400 Hz (Set by parameter constant.)																	
Power supply characteristics																		
Rated voltage (V) Rated frequency (Hz)	3-phase, 380 to 460 VAC, 50/60 Hz																	
Allowable voltage fluctuation	-15 to 10%																	
Allowable frequency fluctuation	±5%																	
Heat generated (kW)	0.06	0.09	0.11	0.13	0.15	0.22	0.36	0.46	0.57	0.66	0.88	1.1	1.3	1.4	1.9	2.4	3.1	4.2
Weight (kg)	Approx. 3	Approx. 3	Approx. 4	Approx. 4.5	Approx. 4.5	Approx. 6.0	Approx. 6.0	Approx. 11	Approx. 11	Approx. 29	Approx. 31	Approx. 44	Approx. 44	Approx. 44	Approx. 61	Approx. 82	Approx. 135	Approx. 145

Control Characteristics

Model 3G3HV-□-CE	AB004 A4004	AB007 A4007	AB015 A4015	AB022 A4022	AB037 A4037	A4055	A4075	A4110	A4150	B4185	B4220	B4300	B4370	B4450	B4550	B4750	B411K	B416K
Power supply harmonic counter-measures	DC reactor connection possible.									Built-in DC reactor 12-phase rectification input								
Control method	Sine wave PWM (high-carrier frequency control)																	
Carrier frequency	2.5 to 15 kHz (6-step switching), other special settings											2.5 to 10 kHz						
Frequency control range	0.1 to 400 Hz																	
Frequency precision (temperature characteristics)	Digital commands: ±0.01% (-10° to 40°C) Analog commands: ±0.1% (25° to ±10°C)																	
Frequency setting resolution	Digital commands: 0.1 Hz Analog commands: 0.1 Hz																	
Output frequency resolution	0.1 Hz																	
Overload capacity	150% of rated current for one minute									120% of rated current for one minute								
Frequency setting signal	0- to 10-VDC (20 kΩ) voltage input or 4- to 20-mA (250 Ω) current input																	
Acceleration/Deceleration time	0.0 to 3,600 s (acceleration and deceleration set separately)																	
Braking torque	Approx. 20% (Up to 125% possible with external braking resistor.)									Approx. 20% (External braking resistor cannot be attached.)								
Voltage/frequency characteristics	Select from 15 types of fixed V/f patterns or set any V/f pattern.																	

Protective Functions

Model 3G3HV-□-CE	AB004 A4004	AB007 A4007	AB015 A4015	AB022 A4022	AB037 A4037	A4055	A4075	A4110	A4150	B4185	B4220	B4300	B4370	B4450	B4550	B4750	B411K	B416K
Motor protection	Protection by electronic thermal.																	
Instantaneous overcurrent protection	Stops at approx. 200% of rated output current.									Stops at approx. 180% of rated output current.								
Overload protection	Stops in one minute at approx. 150% of rated output current.									Stops in one minute at approx. 120% of rated output current.								
Overvoltage protection	Stops when main-circuit DC voltage is approx. 410 V (or 820 V for 400-V class).																	
Undervoltage protection	Stops when main-circuit DC voltage is approx. 190 V (or 380 V for 400-V class).																	
Momentary power interruption compensation (selection)	Stops at 15 ms or more. By means of an operating mode selection, operation can be continued if recovery occurs within 2 seconds.																	
Cooling fin overheating	Protection by thermistor.																	
Grounding protection	Protection by electronic circuits (detection at approx. 50% of rated output current).																	
Charge indicator (internal LED)	Lit when rated DC voltage is approx. 50 V or more.																	

Environment

Model 3G3HV-□-CE	AB004 A4004	AB007 A4007	AB015 A4015	AB022 A4022	AB037 A4037	A4055	A4075	A4110	A4150	B4185	B4220	B4300	B4370	B4450	B4550	B4750	B411K	B416K
Location	Indoors (no corrosive gas, oil spray, metallic dust, etc.)																	
Ambient operating temperature	-10° to 45°C (NEMA type: -10° to 40°C)									-10° to 45°C (Open-chassis type)								
Ambient operating humidity	90% RH (with no condensation)																	
Storage temperature	-20° to 60°C																	
Altitude	1,000 m max.																	
Vibration with-stand	Vibration frequency less than 20 Hz, 9.8 m/s ² , 1G max.; 20 to 50 Hz, 2 m/s ² , 0.2G max																	
Protective structure	Both NEMA1 type: IP20 and open-chassis type: IP00									Open-chassis type: IP00								

3-2 Input Noise Filter Specification

Noise Filter List for EMC Directives

Inverter model 3G3FV/3G3HV	Noise filter (manufactured by Schaffner)			
	Model	Rated current (A)	Weight (kg)	Dimensions (W×D×H) (mm)
A4004-CE	3G3FV-PFS4874-7-07	7	1.1	50×126×255
A4007-CE				
A4015-CE				
A4022-CE	3G3FV-PFS4874-18-07	18	1.7	55×142×305
A4037-CE				
A4055-CE	3G3FV-PFS4874-30-07	30	2.0	60×150×335
A4075-CE				
A4110-CE	3G3FV-PFS4874-42-07	42	3.0	70×185×329
A4150-CE				
B4185-CE	3G3FV-PFS4874-55-07	55	3.3	80×185×329
B4220-CE	3G3FV-PFS4874-75-34	75	4.3	80×220×329
B4300-CE				
B4370-CE	3G3FV-PFS4874-100-35	100	5.7	90×220×379
B4450-CE	3G3FV-PFS4874-130-35	130	8.0	110×240×439
B4550-CE	3G3FV-PFS4874-180-07	180	11	110×240×438
B4750-CE	3G3FV-PFS4874-300-99	300	15	300×564×160
B411K-CE	3G3FV-PFS4874-400-99	400	22	300×564×160
B416K-CE				
AB004-CE	3G3HV-PFS4971-10-07	10	0.7	57.5×156×45.4
AB007-CE	3G3HV-PFS4971-20-07	20	1.0	85.5×119×57.6
AB015-CE				
AB022-CE	3G3HV-PFS4971-40-07	40	3.0	90×246×65
AB037-CE				

External Dimensions of Input Noise Filters

- 3G3FV-PFS4874-7-07 to PFS4874-55-07

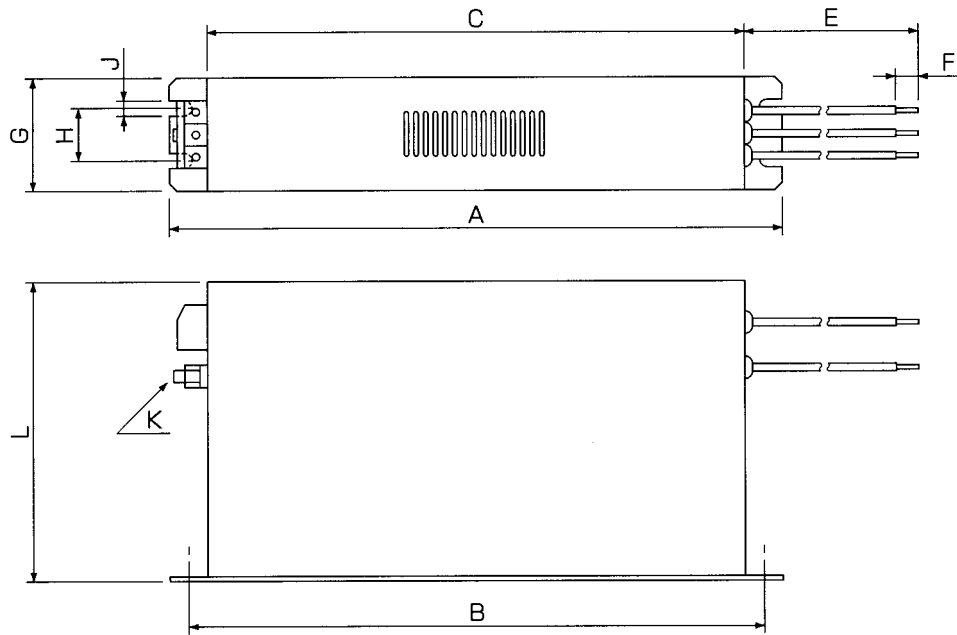

Model 3G3FV-	A	B	C	E	F	G	H	J	K	L
PFS4874-7-07	255	240	225	300±10	9	50	25	6.5	M5	126
PFS4874-18-07	305	290	275	300±10	9	55	30	6.5	M5	142
PFS4874-30-07	335	320	305	400±10	9	60	35	6.5	M5	150
PFS4874-42-07	329	314	300	500±10	12	70	45	6.5	M6	185
PFS4874-55-07	329	314	300	500±10	12	80	55	6.5	M6	185

• 3G3FV-PFS4874-75-34 to PFS4874-130-35

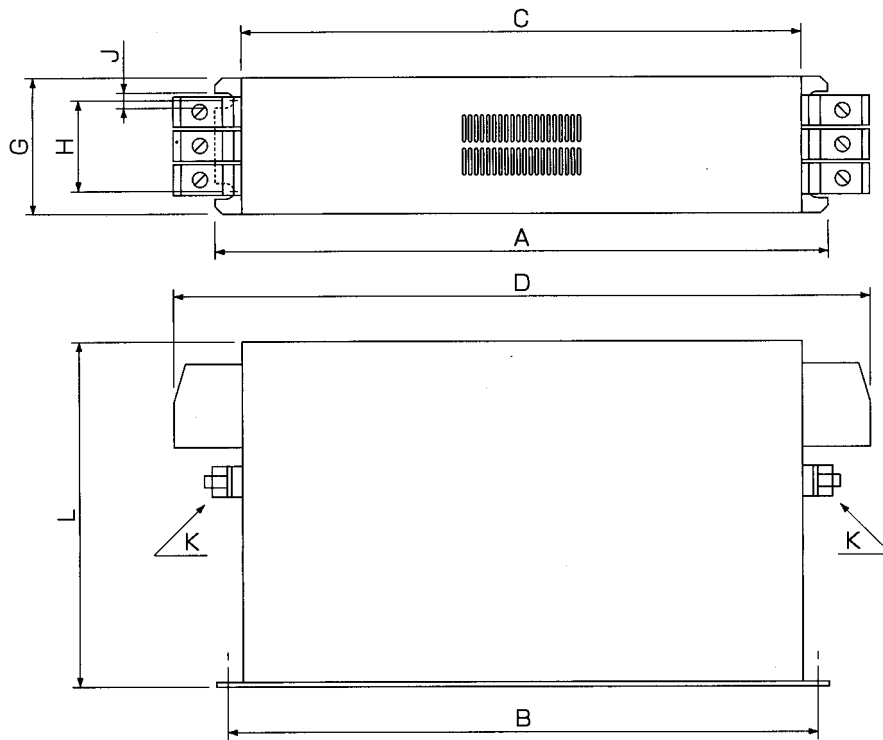

Model 3G3FV-	A	B	C	D	G	H	J	K	L
PFS4874-75-34	329	314	300	377	80	55	6.5	M6	220
PFS4874-100-35	379	364	350	436	90	65	6.5	M10	220
PFS4874-130-35	439	414	400	486	110	80	6.5	M10	240

● 3G3FV-PFS4874-180-07

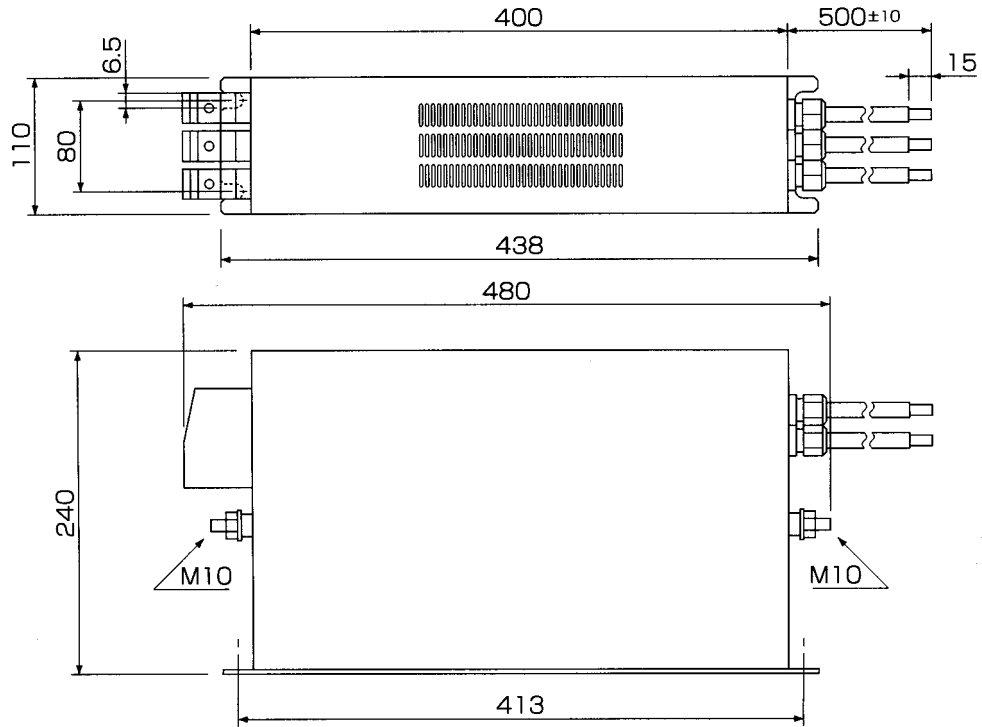

● 3G3FV-PFS4874-300-99/PFS4874-400-99

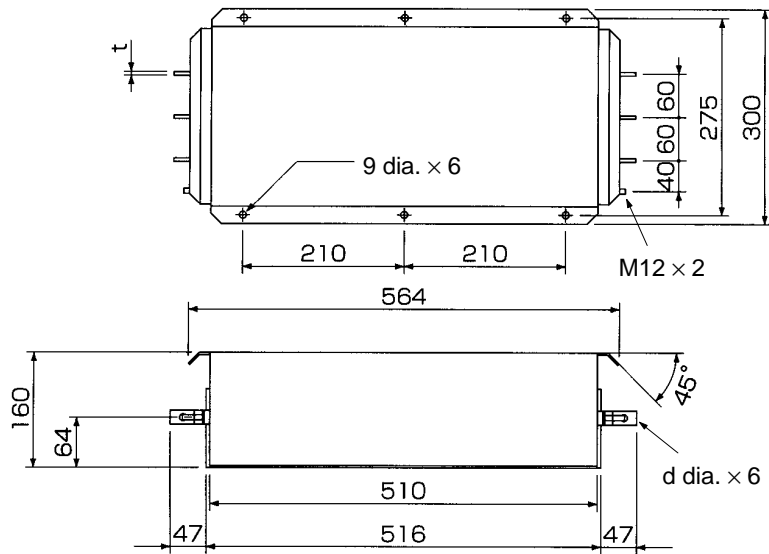

Model 3G3FV-	t	d
PFS4874-300-99	5	8.5
PFS4874-400-99	6	10.5

● 3G3HV-PFS4971-10-07 for Single-phase 200-V Class (0.4 kW)

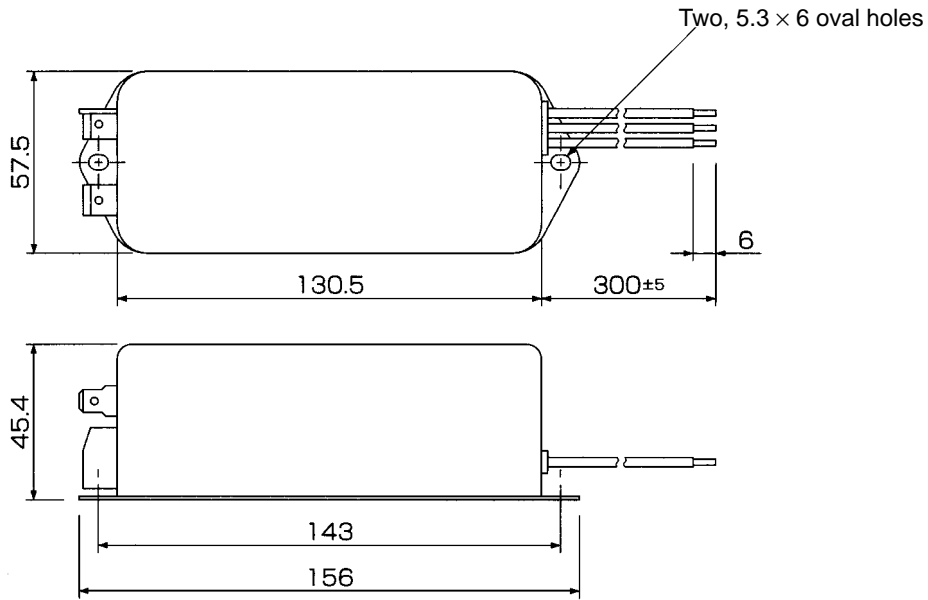

● 3G3HV-PFS4971-20-07 for Single-phase 200-V Class (0.75 and 1.5 kW)

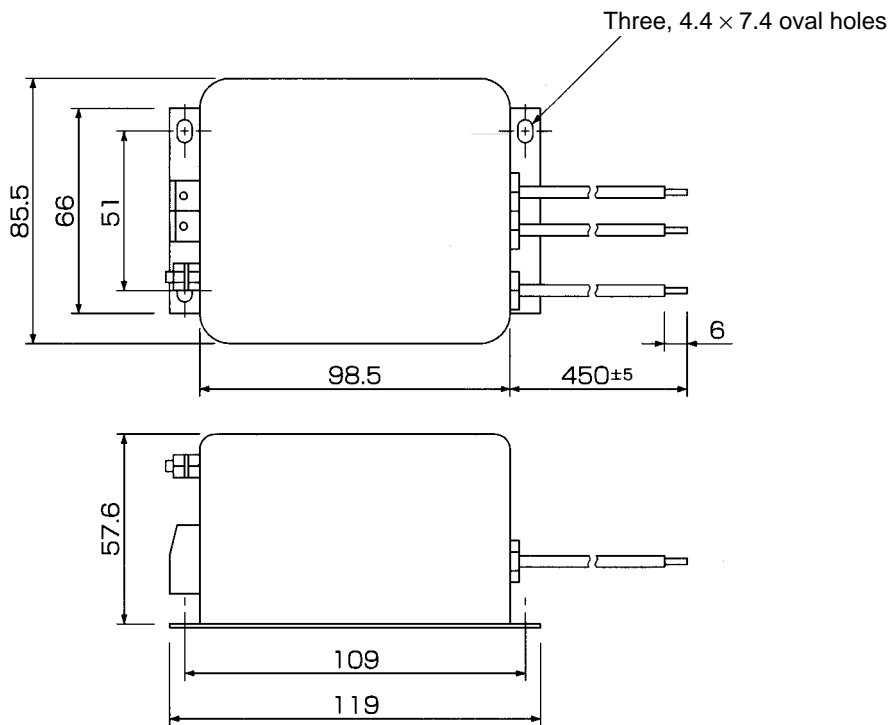

- 3G3HV-PFS4971-40-07 for Single-phase 200-V Class (2.2 and 3.7 kW)

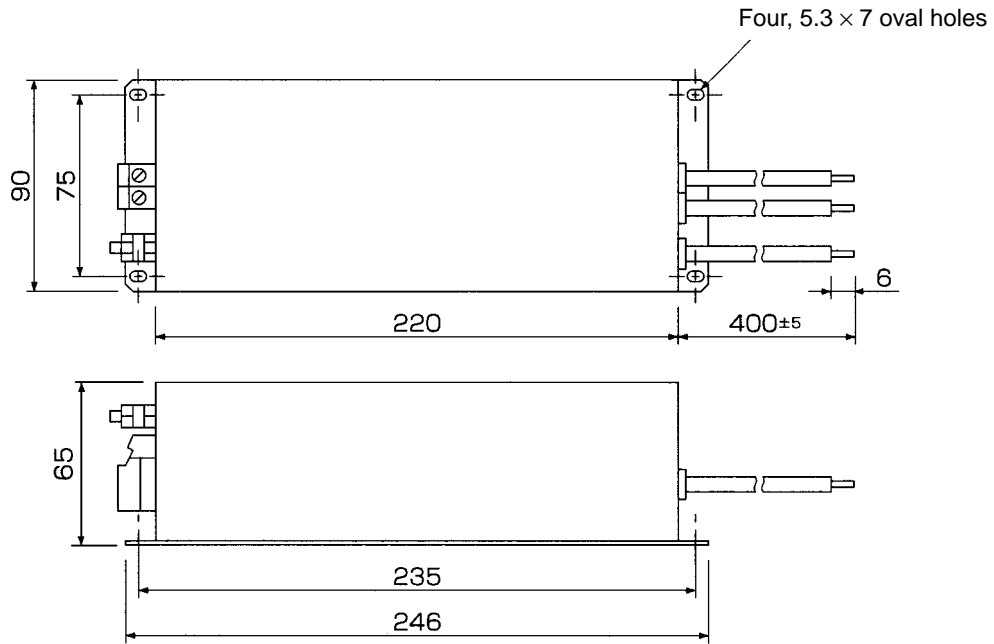

Index

A-B

- AC Reactor, 2-33
- Braking Resistor, 2-41
- Braking Resistor Unit, connecting, 2-42
- Braking Unit, connecting, 2-42
 - parallel, 2-43

C

- cables, length, 2-35
- capacitors, harmonics, 2-37
- cautions
 - installation, 2-7
 - wiring, 2-9
- connection diagram, 3.7- to 15-kW output, 2-18
- control circuit
 - terminals
 - 3G3FV, 2-14
 - 3G3HV, 2-17
 - wiring, 2-45

D-E

- Digital Operator
 - attaching, 2-12
 - removing, 2-10
- dimensions, 2-2
- electromagnetic switch, 2-34
- EMC Directives, conformance, 1-3
 - noise filters, 2-26, 3-6

F-G

- front cover
 - mounting, 2-11
 - removing, 2-10
 - for Inverter with 18.5-kW output or more, 2-12
- ground, wiring, 2-36
- ground fault interrupter, 2-32

H-I

- harmonics, 2-37
 - 12-pulse rectification, 2-40
 - capacitors, 2-37
 - countermeasures, 2-38
 - Inverter, 2-38
 - rectifiers, 2-37
- input fuse, 2-30
- installation, 2-7
 - conditions, 2-8
 - NEMA1 Type, 2-8
 - Open Chassis Type, 2-8
 - orientation, 2-7
 - space, 2-7

L-M

- Low-voltage Directives. *See* LVD Directives
- LVD Directives, conformance, 1-3
 - input fuse, 2-30
- magnetic contactor, 2-33, 2-34
- main circuit
 - input side wiring, 2-32
 - output side wiring, 2-34
 - terminals
 - 3G3FV, 2-13
 - 3G3HV, 2-16
- models, list, 1-2

N-O

- NEMA1 Type, installation conditions, 2-8
- noise filter, 2-26, 3-6
 - output side, 2-34
 - LC/RC, 2-34
- nomenclature, 1-5
- Open Chassis Type, installation conditions, 2-8

P-R

- phase advance capacitor, 2-34
- power supplies, input, connecting, 2-33
- reactors
 - harmonics, countermeasures, 2-38
 - wiring, 2-39
- rectification, 12-pulse, countermeasures against harmonics, 2-40
- rectifiers, harmonics, 2-37

Index

S-T

solderless terminals, round
 control circuit, 2-44
 main circuit, 2-25

specifications
 3G3FV, 3-2
 3G3HV, 3-4
 noise filter, 3-6

surge absorber, 2-33

temperature, 2-8

terminals, 1-6
 configuration, 2-13
 control circuit
 3G3FV, 2-14
 3G3HV, 2-17
 main circuit
 3G3FV, 2-13
 3G3HV, 2-16

thermal relay, 2-34

transformers, 12-pulse rectification, 2-40

V-W

ventilation, 2-8

warnings
 installation, 2-7
 wiring, 2-9

wires, sizes
 control circuit, 2-44
 main circuit, 2-23

wiring
 connection diagram, 3.7- to 15-kW output, 2-18
 control circuit, 2-44
 main circuit, 2-23
 reactors, 2-39

Revision History

A manual revision code appears as a suffix to the catalog number on the front cover of the manual.

Cat. No. I520-E1-1
↑
Revision code

The following table outlines the changes made to the manual during each revision. Page numbers refer to the previous version.

Revision code	Date	Revised content
1	April 1997	Original production